

**SECTION 3**

Note: Click on the page number(s) to jump to the first page of that subject.

**GENERAL**

Residential Service Routing Guide..... 3-1-8 to 3-1-11  
Secondary Service Entrance Details ..... 3-2-11  
Multiple Service Cabinets (Tap Boxes)..... 3-2-12 to 3-2-14  
Overhead to Underground Conversion ..... 3-2-15 and 3-2-16  
D1.9 Electric Vehicle Rate ..... 3-2-17  
Customer Installation Guidelines..... 3-3-1 to 3-3-9

**METER ENCLOSURES**

1  $\Phi$  CL 200 Meter Installation..... 3-4-1  
1  $\Phi$  CL 200, 2 Position Horizontal Meter Installation..... 3-4-3.1  
1  $\Phi$  CL 320 Meter Installation..... 3-4-3.2  
Line Conductor Termination..... 3-4-4

**CABLE POLES & SERVICE MOUNTS**

OH Fed UG Service to Pedestal (Truck Accessible Locations) ..... 3-4-5  
OH Fed UG Service to Pedestal (Non-Truck Accessible Locations) ..... 3-4-5.1  
Post Mounted Services..... 3-4-6  
Pedestal Mounted Services 200 Amp ..... 3-4-6.1  
OH Fed UG Services (Truck Accessible Locations) ..... 3-4-7 to 3-4-9  
OH Fed UG Services (Non-Truck Accessible Locations)..... 3-4-7.1 to 3-4-9.1  
Conductor Identification ..... 3-4-11  
Temporary Service Pedestals..... 3-5-11 and 3-5-12  
Secondary Installation Procedures ..... 3-5-15 to 3-5-18

**PADMOUNT FOUNDATIONS**

Transformer Pad Specifications..... 3-6-1 to 3-6-6  
Grounding Specifications..... 3-6-9  
Support Posts and Anchor Bolts ..... 3-6-10  
Box Pad Guidelines..... 3-6-12 to 3-6-13  
Foundation Installation Requirements ..... 3-6-14 to 3-6-15  
Equipment Clearances ..... 3-7-11 to 3-7-12

**SECTION 3 (Cont.)**

**SERVICE EQUIPMENT**

Preconstruction Meter Mount ..... 3-12-1 to 3-12-4  
CATV Power Supplies..... 3-13-11  
Mobile Home Service ..... 3-14-17 to 3-14-22  
Pedestal Mounted Service Over 200 Amps..... 3-14-25  
Telephone Company Power Pedestal..... 3-15-1 to 3-15-4  
Cellular Tower Services ..... 3-15-5 and 3-15-6  
High Rise Transformers ..... 3-15-7 and 3-15-8

**RESIDENTIAL UNDERGROUND SERVICE ROUTING**  
**FOR REAR LOT DISTRIBUTION**

**NOTES:**        *(All notes refer to Rear Lot URD routing guide on Page 3-1-9.)*

1. Where patio type doors or window walls exist, assume that a patio or a deck will be built.
2. Trenching cannot be done on an adjacent lot except within the easement where necessary to reach pedestal or transformer.
3. Conduit is required when cable will pass under existing pavement, sidewalks, driveways, etc. When installed, conduit is at the customer's expense.
4. Refer to SIM-ESIG Pages 3-3-1 through 3-4-1 for wiring specifications.
5. This drawing shows services installed from underground residential distribution but also applies to underground services from overhead distribution.
6. When a proposed detached garage is to be on the same side of the lot as the service pedestal, 30 feet of duct is required to protect the cable while the garage is under construction. Install duct 18 inches inside property line. Duct is furnished and installed by DTE Electric at the customer's expense.
7. Services shall not be installed diagonally. Install cable 18 inches inside property line (not in easements) parallel to the lot line to a point perpendicular to the meter location.
8. The acceptable meter location shall be the area along the side of the house nearest the service pedestal and up to 3 feet of the rear of the house. Avoid fenced in areas wherever possible.
9. DTE Electric Planner must approve locations outside the acceptable area. A contribution will include customer furnished and installed duct (with fish line) from the edge of the acceptable area continuous to the meter box, plus a non-refundable contribution for pulling the service cable in the customer-installed duct. Total maximum bending degrees for customer-installed duct is 270. This figure includes the 90-degree bend at the riser.
10. The customer shall have the option of furnishing trench and/or conduit for a new residential service providing that it complies with the above guidelines and with specifications acceptable to DTE Electric Company.

**DTE ELECTRIC COMPANY ASSUMES NO RESPONSIBILITY FOR INJURY  
OR DAMAGE ARISING FROM THE USE OF THESE SPECIFICATIONS.**

RESIDENTIAL UNDERGROUND SERVICE ROUTING GUIDE  
REAR LOT U.R.D.

SEE PAGE 3-1-8 FOR NOTES

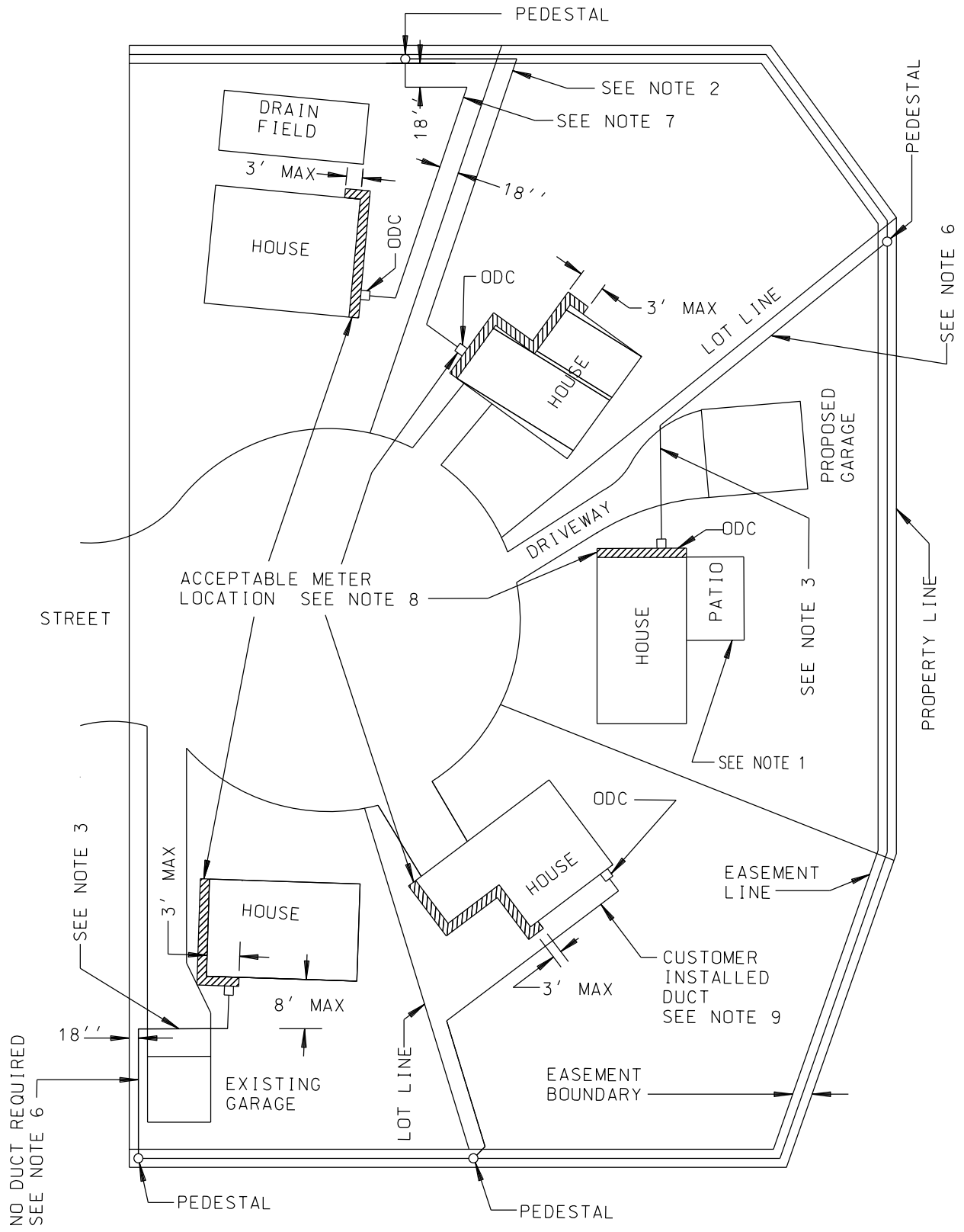

**RESIDENTIAL UNDERGROUND SERVICE ROUTING**  
**FOR FRONT LOT DISTRIBUTION**

**NOTES:**       *(All notes refer to Front Lot URD routing guide on Page 3-1-11.)*

1. Required meter height is 3' 6" from center of meter face to final grade.
2. The acceptable location for the outdoor meter cabinet shall be the area along the front half of the side of the house nearest the temporary cable marker, the front wall, or 3 feet from the front wall on the side opposite the temporary cable marker. Avoid fenced in areas wherever possible.
3. DTE Electric Planner must approve locations outside the acceptable area. A contribution will include customer furnished and installed duct (with fish line) from the edge of the acceptable area continuous to the meter box, plus a non-refundable contribution for pulling the service cable in the customer-installed duct. Total maximum bending degrees for customer-installed duct is 270. This figure includes the 90-degree bend at the riser.
4. Refer to SIM-ESIG Pages 3-3-1 through 3-4-1 for wiring specifications.
5. Any bond between the meter enclosure and joint users that interferes with removing the cover on the meter box is a violation of NEC 250.94 (3). The joint user who created the violation must correct it.
6. This drawing shows services installed from underground residential distribution but also applies to underground services from overhead distribution.
7. The temporary cable marker is to be removed when the service cable is installed.
8. Services shall not be installed diagonally. Install cable 18 inches inside property line (not in easements) parallel to the lot line to a point perpendicular to the meter location.
9. The customer shall have the option of furnishing trench and/or conduit for a new residential service providing that it complies with the above guidelines and with specifications acceptable to DTE Electric Company.

**DTE ELECTRIC COMPANY ASSUMES NO RESPONSIBILITY FOR INJURY  
OR DAMAGE ARISING FROM THE USE OF THESE SPECIFICATIONS.**

RESIDENTIAL UNDERGROUND SERVICE ROUTING GUIDE  
FRONT LOT U.R.D.

SEE PAGE 3-1-10 FOR NOTES

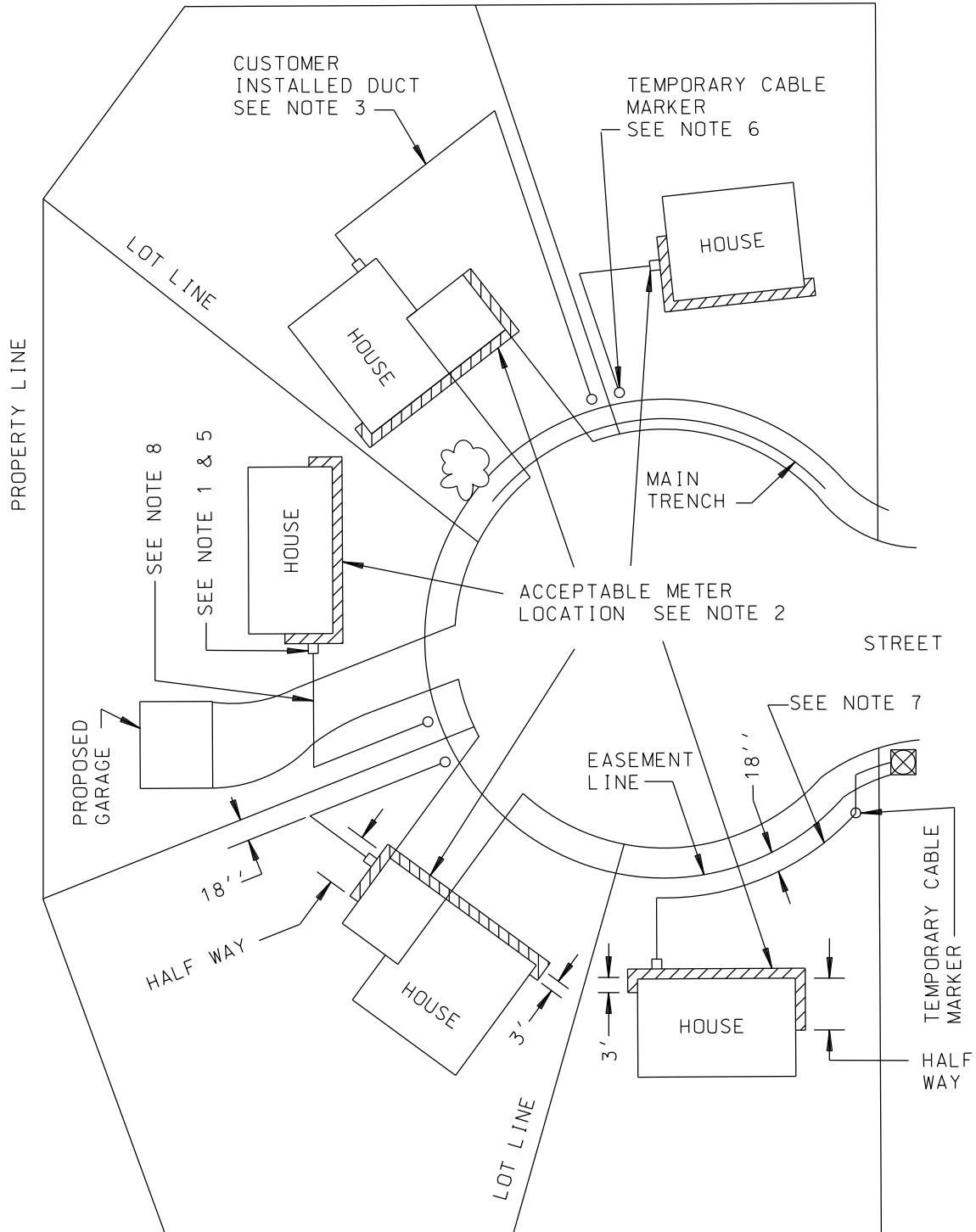

DETAILS FOR UNDERGROUND SECONDARY SERVICE ENTRANCES

90<sup>33</sup>/<sub>64</sub> GALV. RIGID CONDUIT OR INTERMEDIATE METAL CONDUIT BEND

GALV. COUPLING & GALV. RIGID CONDUIT OR INTERMEDIATE METAL CONDUIT

SEE PAGE 3-3-6 FOR CONDUIT SIZING

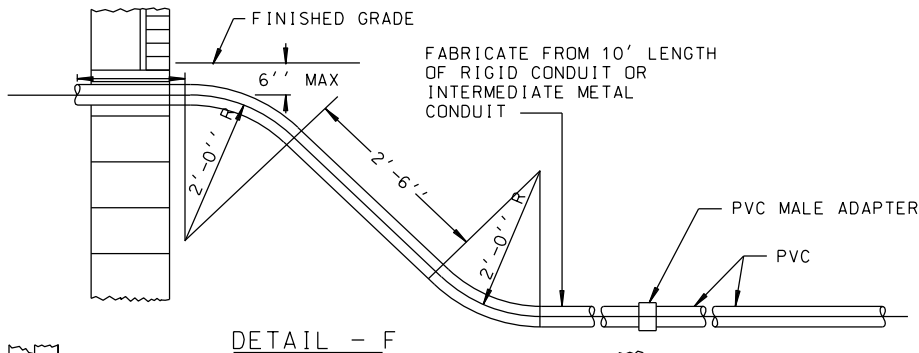
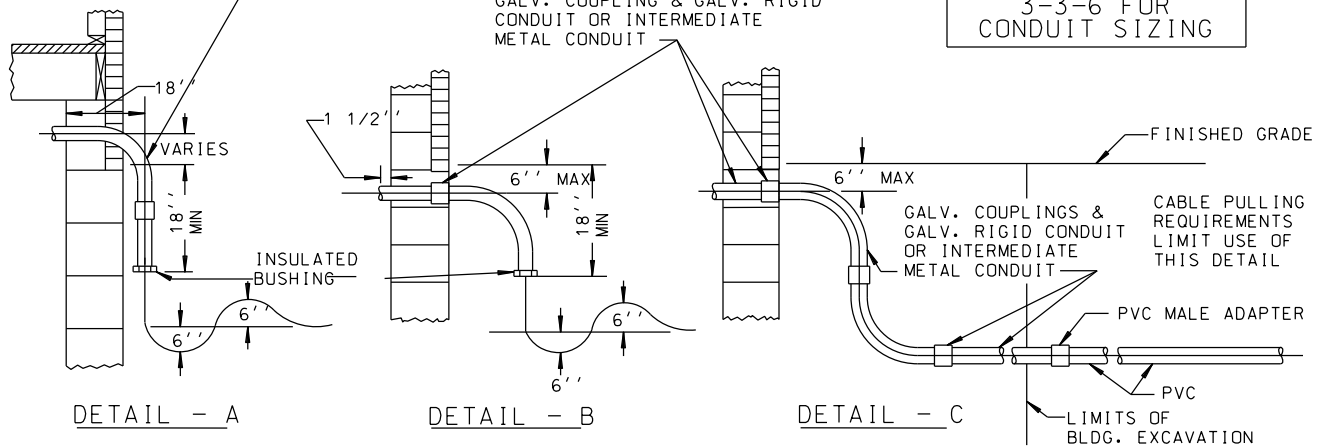

SEE 3-4-1 THROUGH 3-4-3.2 FOR DETAILS

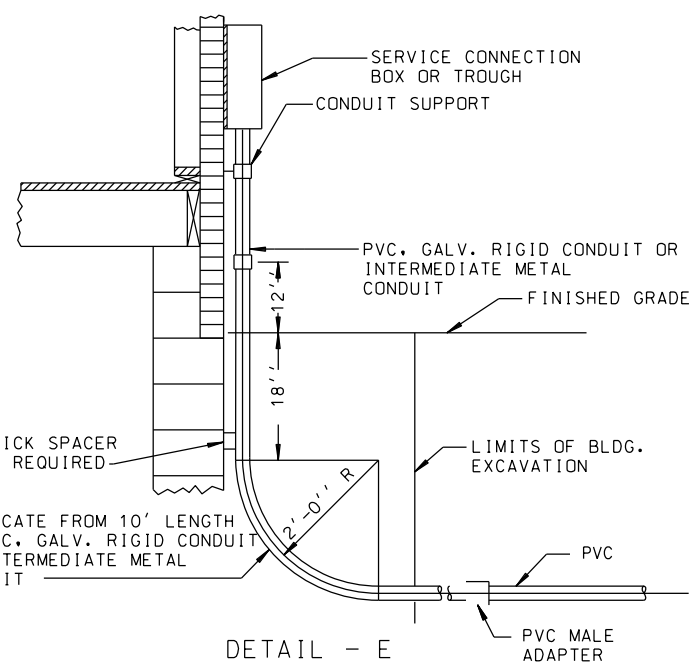
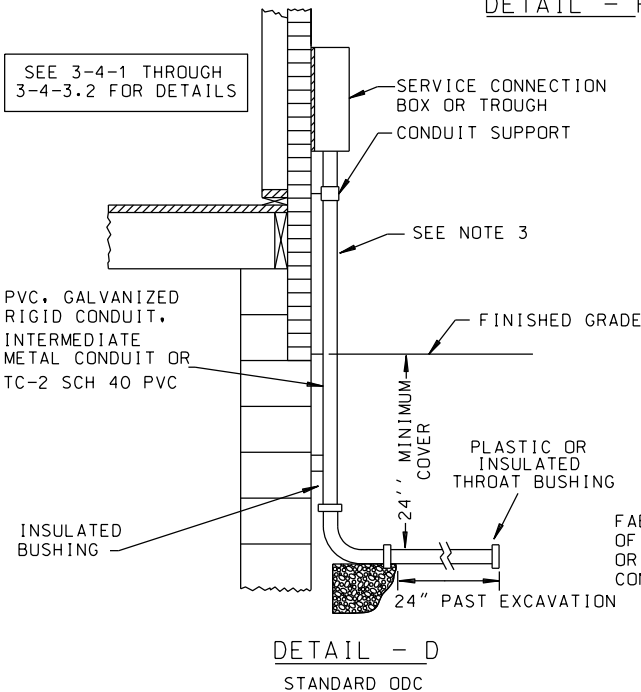

NOTES:

- 1 - ALL EQUIPMENT SHOWN IN THESE DETAILS IS FURNISHED AND INSTALLED BY THE CUSTOMER. CONSULT POLICY (IN THIS SECTION) FOR SERVICE CONDUCTOR INSTALLATION AND OWNERSHIP.
- 2 - DIRECT BURIED CABLE IS SHOWN LOOPED VERTICALLY, HOWEVER SETTLING SLACK CAN ALSO BE SNAKED HORIZONTALLY.
- 3 - RISERS SHALL NOT BE CONCEALED OR RECESSED INTO BUILDING WALLS.

DTE ELECTRIC COMPANY ASSUMES NO RESPONSIBILITY FOR INJURY OR DAMAGE ARISING FROM THE USE OF THIS SPECIFICATION DIAGRAM.

SERVICE TAP BOX  
SINGLE OR 3 PHASE

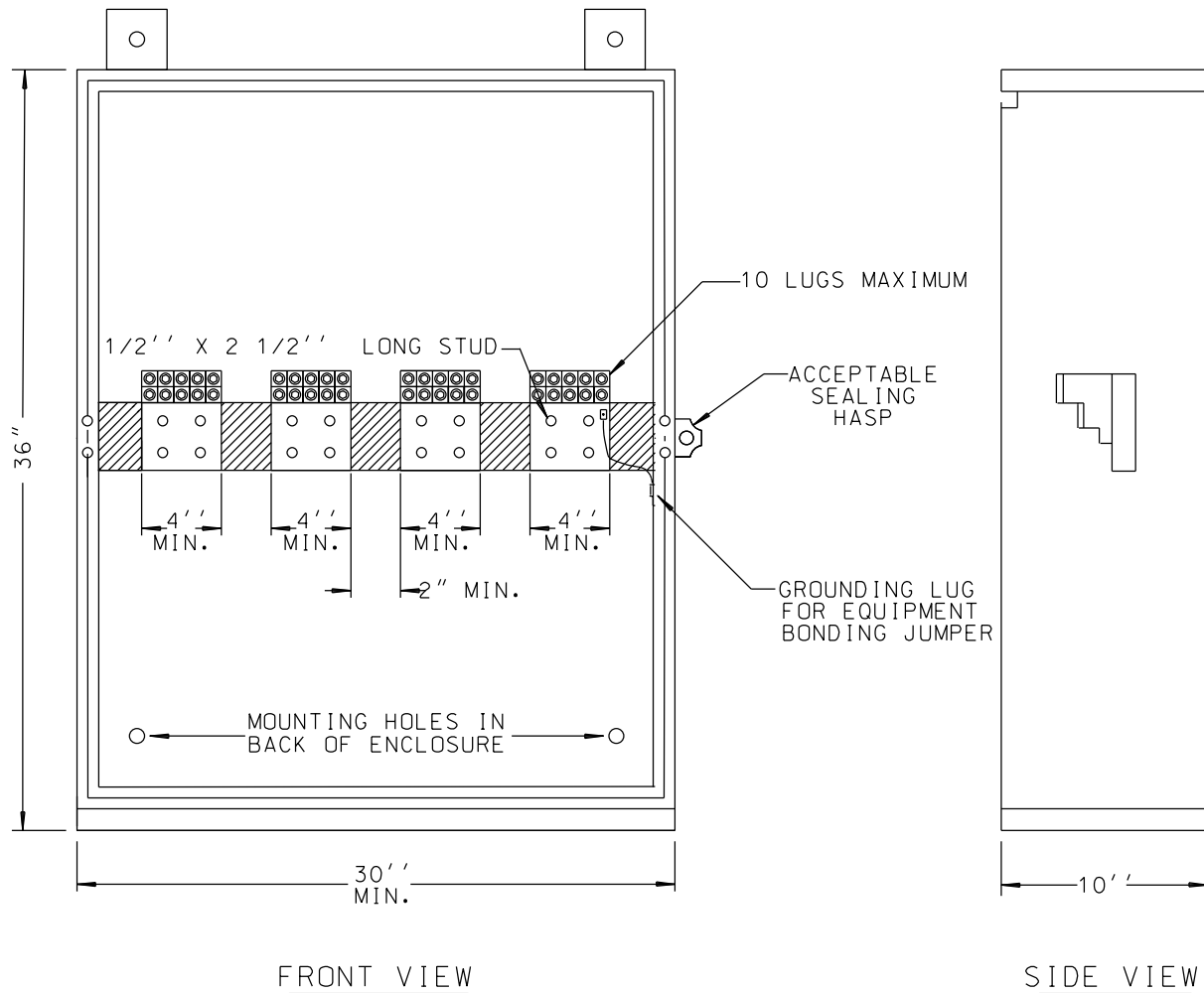

FRONT VIEW

SIDE VIEW

NOTES:

1. CABINET WILL BE FURNISHED AND INSTALLED BY CUSTOMER.
2. CABINET WILL BE MADE OF 14 GAUGE STEEL PER NEMA 3R CONSTRUCTION STANDARDS.
3. THE DOOR OF THE TAP BOX MUST BE EQUIPPED WITH A DTE APPROVED SEALABLE LATCH.
4. INVERT CABLE CONNECTIONS FOR SERVICE CONNECTION AT TOP.
5. CUSTOMER TO PROVIDE EQUIPMENT BONDING JUMPER PER NEC ARTICLE 250.
6. ALL BUS BARS WILL BE FLAT TO FRONT.
7. ONLY ONE SERVICE ALLOWED PER LUG.

DTE ELECTRIC COMPANY ASSUMES NO RESPONSIBILITY FOR INJURY OR DAMAGE ARISING FROM THE USE OF THIS SPECIFICATION DIAGRAM.



SECONDARY CONNECTION CABINET  
METER CONDUIT INSTALLATION - WEATHERPROOF TROUGH

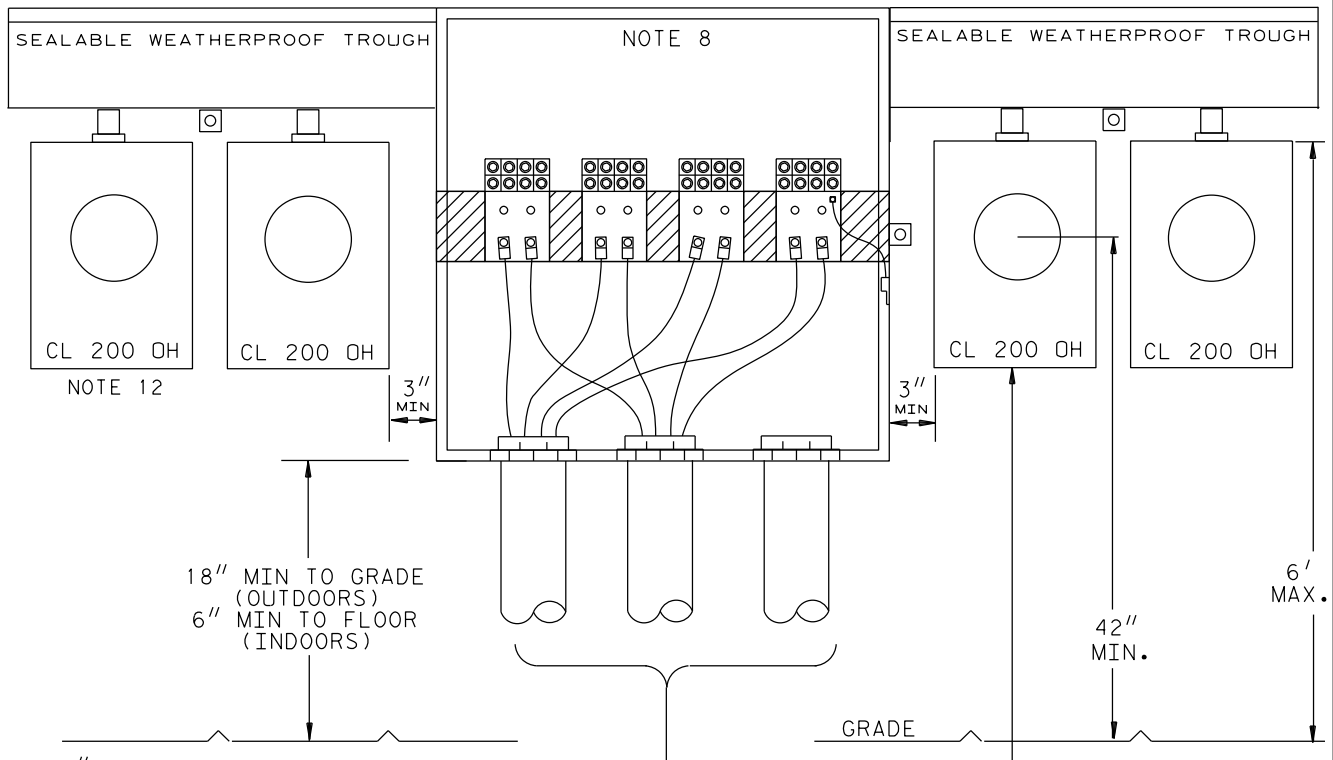

1-4" CONDUIT FOR EACH 400 AMPS OF CABINET CAPACITY OR PART THEREOF FOR DTE ELECTRIC SERVICE CONDUCTORS, PLUS (1) ADDITIONAL 4" CONDUIT FOR EACH SECONDARY CONNECTION CABINET.

**NOTES:**

1. CABINET AND TROUGHS FURNISHED AND INSTALLED BY CUSTOMER.
2. EQUIPMENT ASSEMBLY DRAWINGS AND RISER DIAGRAMS MUST BE SUBMITTED TO DTE ELECTRIC FOR ACCEPTANCE PRIOR TO INSTALLATION.
3. CABINETS AND TROUGHS SHOWN SHALL CONTAIN ONLY UNMETERED LINE CONDUCTORS AND BE SEALABLE WITH ACCEPTABLE SEALING HASPS. SEE PAGES 5-6-9 AND 5-6-10. ALL WIRING AND TAPS TO METERS INSTALLED BY CUSTOMER.
4. ALL CONDUIT AND NIPPLE ENTRIES TO TROUGHS, CABINETS AND BOXES MUST BE MADE WITH WEATHERPROOF HUBS, CONNECTORS AND LOCKNUTS LISTED FOR THE APPLICATION.
5. ALL GROUNDING AND BONDING MUST CONFORM TO NEC 250.
6. ONLY ONE SERVICE ALLOWED PER LUG.
7. CABINETS EXCEEDING 1600 AMPS CAPACITY WILL BE THE FREE STANDING TYPE
8. WALL MOUNTED TAP BOXES OF 800-1600 AMP CAPACITY ARE INTENDED TO SERVE MULTIPLE SELF-CONTAINED METERS ONLY. CT CABINETS SHOULD BE SERVED DIRECTLY FROM THE PADMOUNT TRANSFORMER. SEE NOTE 10 FOR THE EXCEPTION. FREE STANDING TAP BOXES OF 1600-4000 AMP CAPACITY ARE AVAILABLE TO SERVE LARGER CONNECTED LOADS INCLUDING CT CABINETS.
9. CONNECTION BETWEEN TROUGH AND ENCLOSURE MUST BE METAL CONDUIT RMC, IMC, OR EMC ACCEPTED
10. DTE ELECTRIC APPROVED TRANSOCKETS MAY BE FED FROM A TAP BOX. TRANSOCKETS SHALL BE TREATED LIKE A SELF CONTAINED METER OF THEIR RATED CLASS. REFER TO 5-4-19 FOR TRANSOCKET SPECIFICATIONS.
11. SELF CONTAINED METERS, CT CABINETS OR TRANSOCKETS FED FROM A TAP BOX SHALL NOT EXCEED THE NAMEPLATE RATING OF THE TAP BOX.
12. ANY BOND BETWEEN THE METER ENCLOSURE AND JOINT USERS THAT INTERFERES WITH REMOVING THE COVER ON THE METER BOX IS A VIOLATION OF NEC 250.94 (3). THE JOINT USER WHO CREATED THE VIOLATION MUST CORRECT THE SITUATION.

DTE ELECTRIC COMPANY ASSUMES NO RESPONSIBILITY FOR INJURY OR DAMAGE ARISING FROM THE USE OF THIS SPECIFICATION DIAGRAM.

SECONDARY CONNECTION CABINET  
METER CONDUIT INSTALLATION

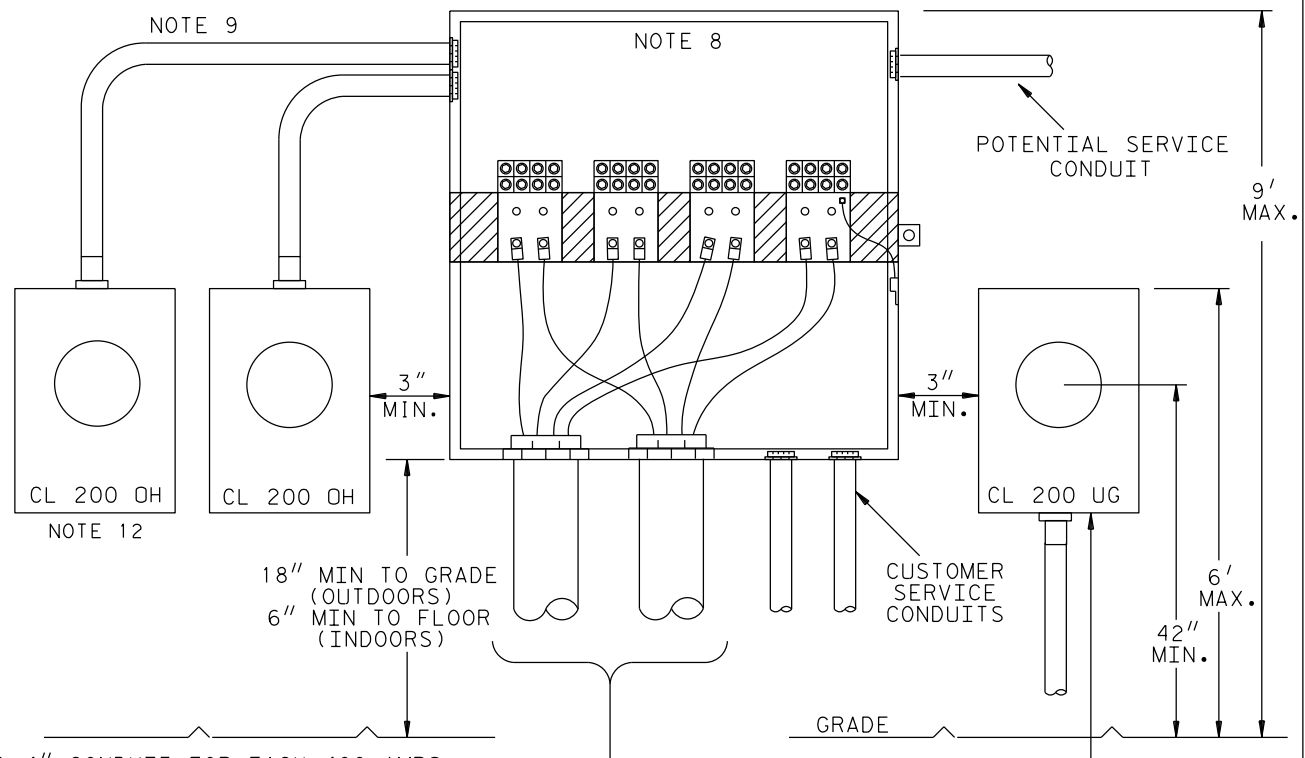

1-4" CONDUIT FOR EACH 400 AMPS OF CABINET CAPACITY OR PART THEREOF FOR DTE ELECTRIC SERVICE CONDUCTORS, PLUS (1) ADDITIONAL 4" CONDUIT FOR EACH SECONDARY CONNECTION CABINET.

**NOTES:**

1. CABINET AND CONDUIT FURNISHED AND INSTALLED BY CUSTOMER.
2. EQUIPMENT ASSEMBLY DRAWINGS AND RISER DIAGRAMS MUST BE SUBMITTED TO DTE ELECTRIC FOR ACCEPTANCE PRIOR TO INSTALLATION.
3. CABINETS AND TROUGHS SHOWN SHALL CONTAIN ONLY UNMETERED LINE CONDUCTORS AND BE SEALABLE WITH ACCEPTABLE SEALING HASPS. SEE PAGES 5-6-9 AND 5-6-10. ALL WIRING AND TAPS TO METERS INSTALLED BY CUSTOMER.
4. ALL CONDUIT AND NIPPLE ENTRIES TO TROUGHS, CABINETS AND BOXES MUST BE MADE WITH WEATHERPROOF HUBS, CONNECTORS AND LOCKNUTS LISTED FOR THE APPLICATION.
5. ALL GROUNDING AND BONDING MUST CONFORM TO NEC 250.
6. ONLY ONE SERVICE ALLOWED PER LUG.
7. CABINETS EXCEEDING 1600 AMPS CAPACITY WILL BE THE FREE STANDING TYPE
8. WALL MOUNTED TAP BOXES OF 800-1600 AMP CAPACITY ARE INTENDED TO SERVE MULTIPLE SELF-CONTAINED METERS ONLY. CT CABINETS SHOULD BE SERVED DIRECTLY FROM THE PADMOUNT TRANSFORMER. SEE NOTE 10 FOR THE EXCEPTION. FREE STANDING TAP BOXES OF 1600-4000 AMP CAPACITY ARE AVAILABLE TO SERVE LARGER CONNECTED LOADS INCLUDING CT CABINETS.
9. CONNECTION FROM TAP BOX TO ENCLOSURE MUST BE METAL CONDUIT - RMC, IMC, OR EMC ACCEPTED. CUSTOMER TO PROVIDE CONDUCTOR BETWEEN METER AND TAP BOX.
10. DTE ELECTRIC APPROVED TRANSOCKETS MAY BE FED FROM A TAP BOX. TRANSOCKETS SHALL BE TREATED LIKE A SELF CONTAINED METER OF THEIR RATED CLASS. REFER TO 5-4-19 FOR TRANSOCKET SPECIFICATIONS.
11. SELF CONTAINED METERS, CT CABINETS OR TRANSOCKETS FED FROM A TAP BOX SHALL NOT EXCEED THE NAMEPLATE RATING OF THE TAP BOX.
12. ANY BOND BETWEEN THE METER ENCLOSURE AND JOINT USERS THAT INTERFERES WITH REMOVING THE COVER ON THE METER BOX IS A VIOLATION OF NEC 250.94 (3). THE JOINT USER WHO CREATED THE VIOLATION MUST CORRECT THE SITUATION.

DTE ELECTRIC COMPANY COMPANY ASSUMES NO RESPONSIBILITY FOR INJURY OR DAMAGE ARISING FROM THE USE OF THIS SPECIFICATION DIAGRAM.

CONTRACTOR METER CONVERSION  
MAINTAINING CONTINUITY OF SERVICE

CUSTOMER CONTRACTOR NOTES:

STEP 1 (PRIOR TO ANY DTE WORK):

1. USE 2" CONDUIT FOR 3/0 AND 3" CONDUIT FOR 350 KCMIL CABLE.
2. INSTALL APPROVED DTE ELECTRIC ENCLOSURE FOR UNDERGROUND SERVICE.
3. CONNECT THE SERVICE ENTRANCE CABLE INTO THE METER BOX ON THE LOAD SIDE.
4. INSTALL TEMPORARY CABLE FROM LOAD SIDE OF EXISTING METER ENCLOSURE TO LOAD SIDE OF NEW METER ENCLOSURE (USE CENTER KNOCKOUT HOLE, IN BOTTOM OF ENCLOSURE). FOR CONTINUITY OF SERVICE, THE SAME TEMPORARY WIRING BETWEEN METERS SHALL APPLY FOR AN UPGRADE FROM A CL200 TO CL320 SERVICE.
5. LEAVE KNOCKOUT FILLER PLUG IN BOTTOM OF METER ENCLOSURE AND INSTALL PLASTIC COVER.
6. DO NOT TAP TOP LUGS OF NEW METER ENCLOSURE.

STEP 5 (AFTER DTE UG SERVICE IS ENERGIZED):

7. REMOVE OLD METER ENCLOSURE AND OLD SERVICE RISER CABLE OR CONDUIT FROM BUILDING.

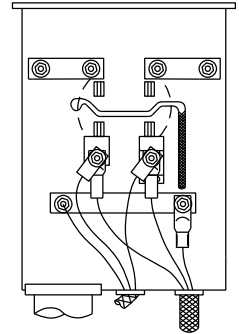

WIRING FOR CL320 SERVICE

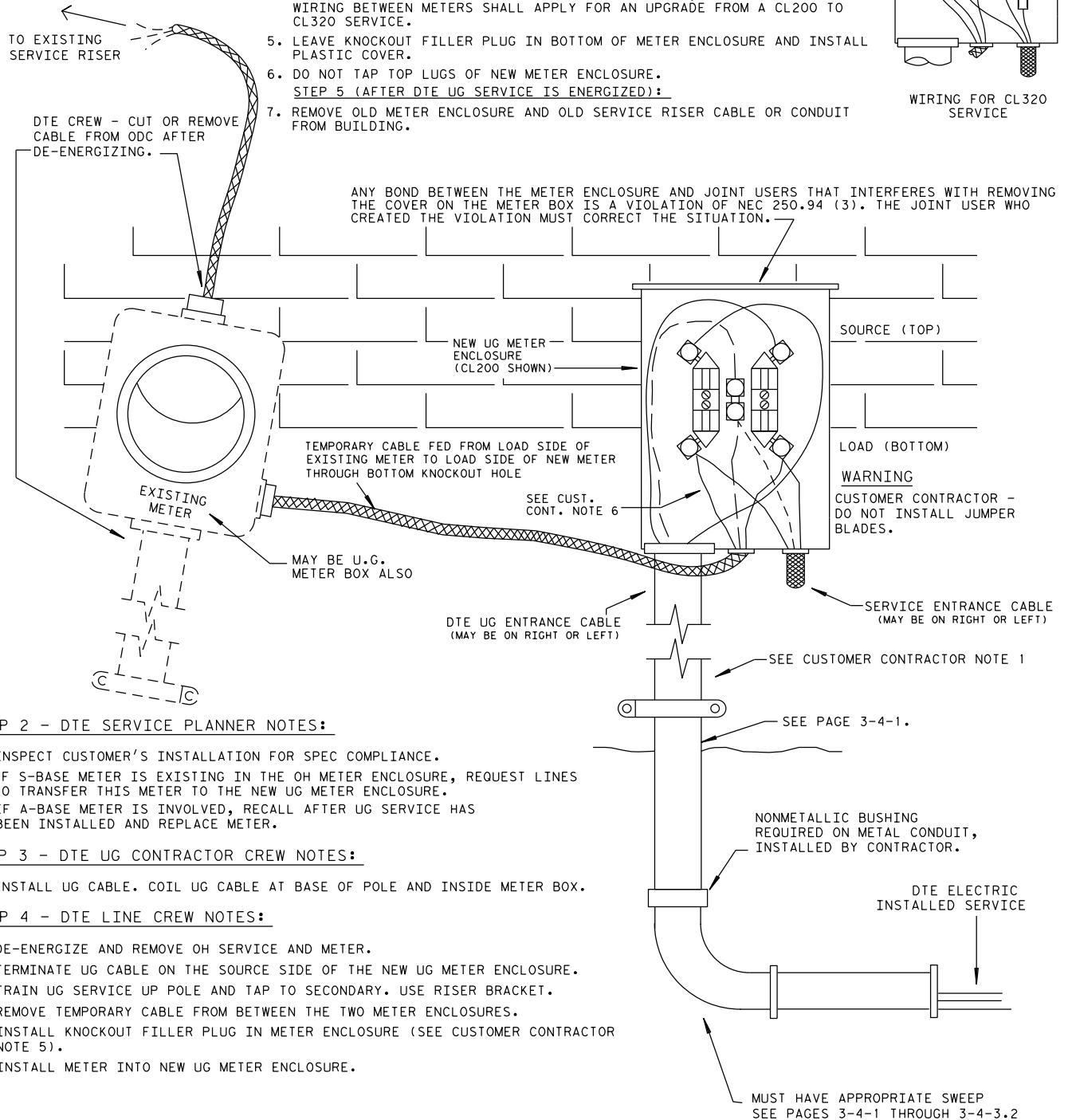

STEP 2 - DTE SERVICE PLANNER NOTES:

1. INSPECT CUSTOMER'S INSTALLATION FOR SPEC COMPLIANCE.
2. IF S-BASE METER IS EXISTING IN THE OH METER ENCLOSURE, REQUEST LINES TO TRANSFER THIS METER TO THE NEW UG METER ENCLOSURE.
3. IF A-BASE METER IS INVOLVED, RECALL AFTER UG SERVICE HAS BEEN INSTALLED AND REPLACE METER.

STEP 3 - DTE UG CONTRACTOR CREW NOTES:

1. INSTALL UG CABLE. COIL UG CABLE AT BASE OF POLE AND INSIDE METER BOX.

STEP 4 - DTE LINE CREW NOTES:

1. DE-ENERGIZE AND REMOVE OH SERVICE AND METER.
2. TERMINATE UG CABLE ON THE SOURCE SIDE OF THE NEW UG METER ENCLOSURE.
3. TRAIN UG SERVICE UP POLE AND TAP TO SECONDARY. USE RISER BRACKET.
4. REMOVE TEMPORARY CABLE FROM BETWEEN THE TWO METER ENCLOSURES.
5. INSTALL KNOCKOUT FILLER PLUG IN METER ENCLOSURE (SEE CUSTOMER CONTRACTOR NOTE 5).
6. INSTALL METER INTO NEW UG METER ENCLOSURE.

DTE ELECTRIC COMPANY ASSUMES NO RESPONSIBILITY FOR INJURY OR DAMAGE ARISING FROM THE USE OF THIS SPECIFICATION DIAGRAM.

1-9-69.1

CONTRACTOR CONVERSION FROM OVERHEAD TO UNDERGROUND  
 MAINTAINING CONTINUITY OF SERVICE  
 SINGLE CUSTOMER WITH EXISTING WATER HEATER AND/OR  
 INTERRUPTIBLE SPACE CONDITIONING

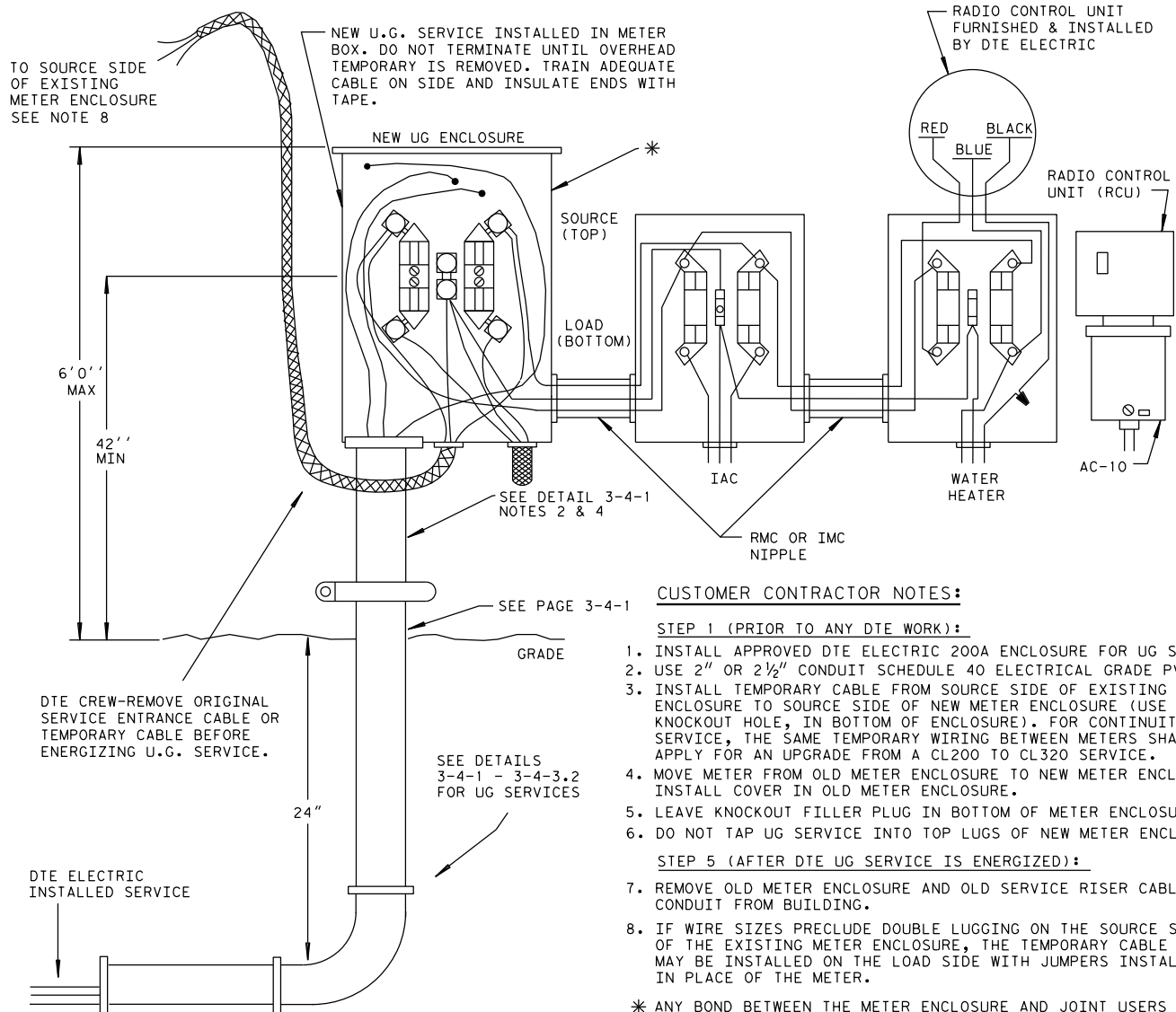

**CUSTOMER CONTRACTOR NOTES:**

STEP 1 (PRIOR TO ANY DTE WORK):

1. INSTALL APPROVED DTE ELECTRIC 200A ENCLOSURE FOR UG SERVICE.
2. USE 2" OR 2½" CONDUIT SCHEDULE 40 ELECTRICAL GRADE PVC.
3. INSTALL TEMPORARY CABLE FROM SOURCE SIDE OF EXISTING METER ENCLOSURE TO SOURCE SIDE OF NEW METER ENCLOSURE (USE CENTER KNOCKOUT HOLE, IN BOTTOM OF ENCLOSURE). FOR CONTINUITY OF SERVICE, THE SAME TEMPORARY WIRING BETWEEN METERS SHALL APPLY FOR AN UPGRADE FROM A CL200 TO CL320 SERVICE.
4. MOVE METER FROM OLD METER ENCLOSURE TO NEW METER ENCLOSURE. INSTALL COVER IN OLD METER ENCLOSURE.
5. LEAVE KNOCKOUT FILLER PLUG IN BOTTOM OF METER ENCLOSURE.
6. DO NOT TAP UG SERVICE INTO TOP LUGS OF NEW METER ENCLOSURE.

STEP 5 (AFTER DTE UG SERVICE IS ENERGIZED):

7. REMOVE OLD METER ENCLOSURE AND OLD SERVICE RISER CABLE OR CONDUIT FROM BUILDING.
8. IF WIRE SIZES PRECLUDE DOUBLE LUGGING ON THE SOURCE SIDE OF THE EXISTING METER ENCLOSURE, THE TEMPORARY CABLE MAY BE INSTALLED ON THE LOAD SIDE WITH JUMPERS INSTALLED IN PLACE OF THE METER.

\* ANY BOND BETWEEN THE METER ENCLOSURE AND JOINT USERS THAT INTERFERES WITH REMOVING THE COVER ON THE METER BOX IS A VIOLATION OF NEC 250.94 (3). THE JOINT USER WHO CREATED THE VIOLATION MUST CORRECT THE SITUATION.

STEP 2 - DTE SERVICE PLANNER NOTES:

1. INSPECT CUSTOMER'S INSTALLATION FOR SPEC COMPLIANCE. IDENTIFY AND MARK RATE (RES, IAC, WTR HTR).
2. INSPECT ALL METER BOX CONNECTIONS TO ASSURE LINE SIDE CONNECTIONS AND AVOID DOUBLE METERING.
3. IF S-BASE METER IS EXISTING IN THE OH METER ENCLOSURE, REQUEST LINES TO TRANSFER THIS METER TO THE NEW UG METER ENCLOSURE.
4. IF A-BASE METER IS INVOLVED, RECALL AFTER UG SERVICE HAS BEEN INSTALLED AND REPLACE METER.
5. CONFIRM CITY/TOWNSHIP APPROVAL IF REQUIRED BY LOCAL MUNICIPALITIES.

STEP 3 - DTE UG CONTRACTOR CREW NOTES:

1. INSTALL UG CABLE. COIL UG CABLE AT BASE OF POLE AND INSIDE METER BOX. DO NOT TERMINATE IN LUGS - TAPE ENDS TO INSULATE CONDUCTORS.

STEP 4 - DTE LINE CREW NOTES:

1. DE-ENERGIZE AND REMOVE OH SERVICE AND METER.
2. TERMINATE UG CABLE ON THE SOURCE SIDE OF THE NEW UG METER ENCLOSURE.
3. TRAIN UG SERVICE UP POLE AND TAP TO SECONDARY. USE RISSER BRACKETS.
4. REMOVE TEMPORARY CABLE FROM BETWEEN THE TWO METER ENCLOSURES.
5. INSTALL KNOCKOUT FILLER PLUG IN METER ENCLOSURE (SEE CUSTOMER CONTRACTOR NOTE 5).
6. INSTALL METER INTO NEW UG METER ENCLOSURE.

DTE ELECTRIC COMPANY ASSUMES NO RESPONSIBILITY FOR INJURY OR DAMAGE ARISING FROM THE USE OF THIS SPECIFICATION DIAGRAM.

CONTRACTOR INSTALLATION OF ELECTRIC VEHICLE METER RATE D1.9  
 FED THRU ADDITIONAL WATER HEATER OR INTERRUPTIBLE AIR CONDITIONING METER

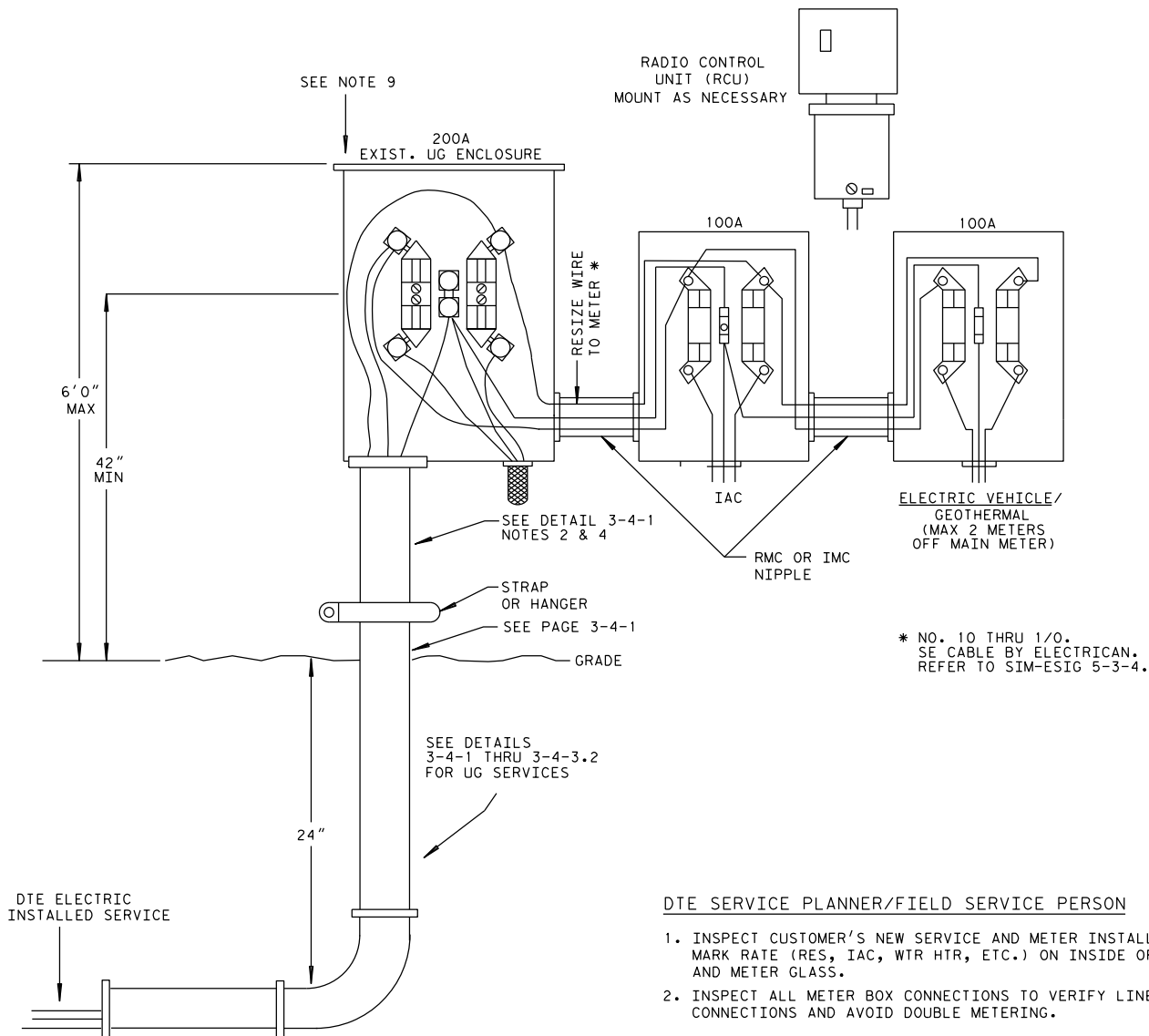

\* NO. 10 THRU 1/0.  
 SE CABLE BY ELECTRICIAN.  
 REFER TO SIM-ESIG 5-3-4.

DTE SERVICE PLANNER/FIELD SERVICE PERSON

1. INSPECT CUSTOMER'S NEW SERVICE AND METER INSTALLATION. MARK RATE (RES, IAC, WTR HTR, ETC.) ON INSIDE OF METER BOX AND METER GLASS.
2. INSPECT ALL METER BOX CONNECTIONS TO VERIFY LINE SIDE CONNECTIONS AND AVOID DOUBLE METERING.

CONTRACTOR NOTES:

1. INSTALL NEW APPROVED METER ENCLOSURE REFER TO SIM-ESIG SUBSECTION 5-8 FOR ACCEPTABLE METERING ENCLOSURES.
2. LEAVE KNOCKOUT FILLER PLUG IN BOTTOM OF METER ENCLOSURE.
3. IT IS THE CUSTOMER'S RESPONSIBILITY TO FURNISH THE METER ENCLOSURE.
4. INTERCONNECTION BETWEEN THE RESIDENTIAL METER AND IAC OR WATER HEATING METER MUST BE SIZED TO SERVE THE CURRENT REQUIREMENTS OF THE CUSTOMER'S CONNECTED LOAD. IN ANY CASE, MINIMUM SIZE ACCEPTABLE IS NO. 8 COPPER OR EQUIVALENT.
5. FOR RATE D1.9 THE CONTRACTOR WILL CONNECT THE SERVICE TO THE LOAD SIDE OF RESIDENTIAL OR IAC WATER HEATING METER LEAVING ENOUGH SLACK TO EASILY REACH THE LINE SIDE TERMINALS. DTE ELECTRIC PERSONNEL WILL MOVE THE CONDUCTORS TO THE LINE SIDE WHEN THE INSTALLATION IS ACCEPTED FOR SERVICE.
6. CONTRACTOR MUST MAINTAIN PROPER METER INSTALLATION CLEARANCE SPECS. REFER TO SIM-ESIG 5-3-1 & 2 FOR PROPER MOUNTING SPECS. I.E. 42" TO CTR OF METER GLASS, 6' MAX TO TOP OF METER CAN, 12" MINIMUM FROM INSIDE AND OUTSIDE CORNERS AND 36" MINIMUM SPACE IN FRONT OF METER.

ADDITIONAL NOTES:

7. IF REQUEST IS ON A CONDOMINIUM UNIT, OWNER MUST OBTAIN PERMISSION FROM HOMEOWNERS ASSOCIATION FOR ADDITIONAL MOUNTING OF METERS.
8. DTE ELECTRIC WILL NOT INSTALL A SEPARATE SERVICE FOR ADDITIONAL METERS IF THERE IS AN OVERLOAD CONDITION SERVICE WIRE OR SPACIAL LIMITATIONS FOR INDIVIDUAL METERS, A MULTIMETER MODULE MAY BE REQUIRED. NOTE: IF ANY OF THESE ISSUES APPLY FOR AN OVERHEAD SERVICE THE CUSTOMER MAY BE REQUIRED TO CONVERT TO AN UNDERGROUND SERVICE.
9. ANY BOND BETWEEN THE METER ENCLOSURE AND JOINT USERS THAT INTERFERES WITH REMOVING THE COVER ON THE METER BOX IS A VIOLATION OF NEC 250.94 (3). THE JOINT USER WHO CREATED THE VIOLATION MUST CORRECT THE SITUATION.
10. EV METER MUST BE INSTALLED, AS SHOWN, NEXT TO THE HOUSE METER. EV METER INSTALLATION SHALL NOT BE ALLOWED ON OUT BUILDINGS SUCH AS DETACHED GARAGES.
11. IF EXISTING METER INSTALLATIONS ARE OVERHEAD, THEN THIS SHALL BE ALLOWED. SEE PAGE 7-14-3 DETAIL B.
12. IF A POLE BARN IS INSTALLED, CONSULT WITH PLANNING.

DTE ELECTRIC COMPANY ASSUMES NO RESPONSIBILITY FOR INJURY OR DAMAGE ARISING FROM THE USE OF THIS SPECIFICATION DIAGRAM.

**CUSTOMER CONTRACTOR UNDERGROUND SERVICE INSTALLATION****1. General.**

- (a) Prior to the construction of any job, the customer or his authorized representative must consult with the DTE Electric Planner at the appropriate Regional Center to determine acceptable construction standards. Failure to do so could result in added expenses, unnecessary delays, or both.
- (b) This specification covers the installation by the customer's electrical contractor of:
  - (1) Customer furnished, owned, and maintained commercial service conductors.
  - (2) Conduit for DTE Electric furnished, installed, owned, and maintained primary or secondary commercial service conductors.
- (c) A DTE Electric Planner will inspect each installation. All material and workmanship must be acceptable to DTE Electric.
- (d) DTE Electric will install conduit in public thoroughfare.

**2. Rules and Regulations.**

When this specification conflicts with local rules, permission from the inspection authority having jurisdiction may be required. See *Rate Book for Electric Service* Rule C6 for DTE Electric policy.

**3. Installation of Secondary Cable.**

- (a) Only one conductor per leg or phase shall be used for loads of 400 amperes or less when conduit is required in public thoroughfares.
- (b) Not more than two conductors per phase shall be paralleled for loads of 400 to 800 amperes when conduit is required in public thoroughfares.
- (c) For *delta* connection, the power leg and neutral may be reduced in size as allowed by the *National Electrical Code*. For *wye* connection, a full size neutral is advisable to allow for changes in building use such as large single phase loads or discharge lighting; however, the *National Electrical Code* does allow reduction of the neutral on a *wye* service. [See NEC 250-24(C).]
- (d) The conductors shall be of sufficient length to make connection to DTE Electric equipment. (See SIM-ESIG 3-5-15.)
- (e) Maximum number of conductors per conduit is eight, except in network areas.

- (f) Maximum number of secondary conductors per phase terminating in a padmount transformer will be as follows:
  - (1) Three-phase (750 kVA and above) .....8
  - (2) Three-phase (500 kVA and below) .....6  
 For 8 cables maximum use terminal extension  
 SAP No. 100015563.  
 (See *UG Lines Construction Standards* 1-9-211.)
  - (3) Single-phase .....4  
 Note: Up to 3/0 AWG--8 cables maximum using  
 setscrew connector SAP No. 100067028 or terminal  
 extension SAP No. 100015563.  
 (See *UG Lines Construction Standards* 1-9-213 & 1-9-214.)
- (g) Maximum conductor size shall be 750 kcmil aluminum or copper.
- (h) Maximum number of conduits per cable pole is three.
- (i) On a cable pole, when paralleling of conductors is permissible, not more than three conductors per phase may be paralleled. A maximum of six conductors may be installed in one conduit. DTE Electric personnel will connect conductors to Company equipment.
- (j) Each conduit shall contain at least one conductor of each phase and one neutral. (Do not install a separate grounding conductor in addition to the neutral.)
- (k) DTE offers a multiple secondary termination cabinet allowing more than 8 sets of conductor terminations. Customer supplies secondary wires to and from cabinet.

**4. Secondary Cable Termination.**

- (a) **Cabinets and Enclosures.** Do *not* use current transformer cabinet or meter enclosure line terminals to connect leads to other CT cabinets or meter enclosures. Use troughs or tap boxes except for the tandem meter assembly shown on page 5-3-6 or for separate space conditioning and water heating rates shown in Section 7. In unusual cases, the DTE Electric Planner may grant an exception.
- (b) **Troughs and Tap Boxes.**
  - (1) **Troughs.** Tap connector assemblies with insulated supports or removable insulated covers are required to connect service cables from underground service conductors to meter boxes. These devices may be attached securely to the enclosure or have preformed insulated boots. Individual tap connectors other than split bolts are acceptable. Power distribution blocks or multi-tap connection blocks with insulated boots are preferred.

- (2) **Tap boxes.** See drawings on pages 3-2-12 to 14 as a guide to this application.
- (3) **Customer switches.** In those installations where the service conductors terminate in the customer’s main disconnect instead of the DTE Electric meter enclosure, the switch must be UL listed for Al-Cu cable termination. See the service equipment assembly drawings in Section 5 for the connecting sequence of main switches and meters. Main switches containing unmetered conductors must be sealable.
- (c) **Cable Turning Radius.** Adequate wire bending space must be provided within enclosures as specified in NEC Table 312.6(B). Supplementary requirements shown on DTE Electric terminal cabinet drawings must also be met.

**5. Mechanical Protection of Secondary Cable on Pole.**

- (a) Rigid nonmetallic conduit, intermediate metal conduit, or PVC conduit may be used for direct-buried cables. Rigid metal conduit is required in traffic areas. (See paragraph 12 this section and pages 3-4-7, 3-4-8, and 3-4-9.)
- (b) Protection provided by the electrical contractor shall extend not less than 8 feet or more than 10 feet above finished grade.

<b>No. of Conductors per Phase per Customer</b>	<b>Size of Phase Conductors</b>	<b>No. of Customers per Pole</b>	
		<b>One</b>	<b>More than One</b>
1	3/0 AWG through 4/0 AWG	page 3-4-7 See Note 1.	page 3-4-8 See Note 1.
1	3/0 AWG through 750 kcmil	page 3-4-7	page 3-4-8
2 See Note 2.	4/0 AWG through 750 kcmil	page 3-4-8	Not permitted
3 See Note 2.	4/0 AWG through 750 kcmil (See 3.)	page 3-4-9	Not permitted

*Notes:*

1. *Minimum size power or neutral conductor allowed with this detail is 3/0 AWG.*
2. *Sizes smaller than 500 kcmil should be paralleled only for power or neutral conductors or to add to existing lighters on service increases.*



**6. Secondary Conductors.**

(a) **General.** Stranded aluminum or copper conductors that meet *Insulated Cable Engineers Association* (ICEA) standards shown below are acceptable. Cables shall be single conductor with nonmetallic sheath. All conductors, including neutral, shall be insulated with heat and moisture resistant material. Conductors shall be marked in compliance with NEC 310-11, particularly as to insulation type.

(b) **ICEA Specifications.**

Rubber.....	S-19-081
Thermoplastic .....	S-61-402
Cross-Linked Polyethylene.....	S-66-524
Ethylene Propylene Rubber .....	S-68-516

(c) **Conductors in Conduit.**

(1) **Fed from secondary cable pole.**

- a. *Acceptable:*  
RHH, RHW, RHW-2--rubber (EPR) or polyethylene (XLP)  
XHHW, XHHW-2--cross-linked polyethylene
- b. *Not Acceptable:*  
TW, THW, THWN, or THHN--thermoplastic

(2) **Fed from transformer or pedestal.**

- a. *Recommended:*  
RHH, RHW, RHW-2--rubber (EPR) or polyethylene (XLP)  
XHHW, XHHW-2--cross-linked polyethylene
- b. *Acceptable:*  
TW, THW, THWN, or THHN--thermoplastic

(3) **Fed from network.**

Customer shall contact the Service Planner to arrange for the purchase and delivery of AC network service cable.

(d) **Direct Buried Conductors.**

- a. *Acceptable:*  
RHH, RHW, RHW-2--cross-linked polyethylene (XLP)  
USE, USE-2--underground service entrance

**7. Conduit.****(a) Acceptable for Cable Protection in Earth.****(1) Installed without encasement or under concrete drives or buildings.**

Rigid galvanized steel  
Schedule 40 or 80 rigid nonmetallic PVC  
Intermediate metal conduit (IMC)--hot dip galvanized

**(2) Installed without encasement in open area or under blacktop.**

Type II underground plastic duct (styrene) or fiber per NEMA TC-2  
Type DB power and communications duct (PVC) per NEMA TC-6 and TC-8

**(3) Installed encased in concrete but *not* under areas subject to vehicular traffic such as concrete drives, aprons, parking areas, etc.**

Type I underground plastic duct (styrene) or PVC per NEMA TC-1  
Type EB power and communications duct (PVC) per NEMA TC-6 and TC-8

**(b) Not Acceptable for Cable Protection in Earth.**

Rigid aluminum conduit  
Aluminum or steel electrical metallic tubing (EMT)

**(c) Conduit Protection at Source.****(1) Sweeps at primary cable poles.**

Rigid galvanized steel  
Schedule 40 or 80 rigid nonmetallic PVC

**(2) Sweeps at secondary cable poles.**

Rigid galvanized steel  
Schedule 40 or 80 rigid nonmetallic PVC  
Intermediate metal conduit (IMC)

**(d) Conduit Protection at Transformer.****Sweeps for primary and secondary.**

Rigid galvanized steel  
Schedule 40 or 80 rigid nonmetallic PVC  
Intermediate metal conduit (IMC)

(e) **Conduit for Single- and Three-Phase Secondary Metered Service.**

The customer is usually required to provide two conduits for the primary conductors to the property line on single- and three-phase padmount transformer installations with single meter secondary service. The second conduit provides for later development and extension of fused loop systems.

There will be no charge to existing customers for installing conductors to close loops or to serve new adjacent customers.

The DTE Electric Planner will indicate the route and location of the conduit.

(f) **Conduit Sizes for DTE Electric Cable.**

Conduit installed by the customer/contractor for conductors that are to be furnished, installed, owned, and maintained by DTE Electric will be as follows:

(See *UG Lines Construction Standards* 1-24-605.)

**Primary:**

Minimum ..... 4 in

**Secondary:**

750 kcmil Al 3-Wire..... 4 in	750 kcmil Cu 4-Wire..... 5 in
350 kcmil Al 4-Wire..... 4 in	750 kcmil Cu 3-Wire..... 5 in
350 kcmil Al 3-Wire..... 3 in	500 kcmil Cu 4-Wire..... 5 in
3/0 AWG Al 4-Wire..... 3 in	500 kcmil Cu 3-Wire..... 4 in
3/0 AWG Al 3-Wire..... 2 in	4/0 AWG Cu 3-Wire..... 2-1/2 in

*Note:* Secondary cable duct for service cables owned and maintained by the building owner and furnished and installed by his contractor may use conductor fill and sweep radius that complies with the NEC. For DTE Electric Installation Standards pertaining to these situations see Service Equipment pages 5-4-5 & 5-4-7.

All of the above conduits can be connected to steel or PVC sweeps using adapters to threaded fittings. PVC cannot be cemented to styrene or vice versa. Rigid galvanized steel, intermediate metal conduit, and Schedule 40 or 80 sweeps can be purchased in 18 in, 24 in, 30 in, 36 in, 48 in, 60 in, and 72 in radius ells.

Ninety degree ell conduit access fittings (types LB, LL, or LR) are not allowed below grade or into the side of meter enclosures; however, with the DTE Electric Planner’s permission, they may be used to go through the wall if straight conduit entry cannot be used. The contractor may be required to assist the DTE Electric crew in pulling conduit runs with such fittings when the service conductors are to be installed, owned, and maintained by DTE Electric.

(g) **Conduit Marking.** Rigid nonmetallic conduit (PVC) shall be marked per NEC 110-21 and 347-17.

**(h) Service and Commercial Feeder Installation.**

- (1) **Trench.** The bottom of the trench should be level without sudden changes that would leave the conduit unsupported during backfill. Backfilling over plastic conduit should be done from the center towards both ends. Trenches for secondary service conductors will be deep enough to assure 24 inches of cover from the top surface of the cable or conduit to finished grade. Trenches for primary conductors will be deep enough to assure 30 inches of cover to grade.
- (2) **Plugs and fish line.** Conduit must be plugged at both ends immediately after installation to prevent entrance of foreign matter or water. The plugs used must be substantial enough to remain in place. If the conductors are to be furnished and installed by DTE Electric, a stout cord such as nylon fish line will be left in the conduit for the DTE Electric crew to pull in their pulling line.
- (3) **Conduit under buildings.** Conduit and conductors shall *not* be run under one building to serve another.
- (4) **Conduit length.** When two-90 degree bends are used to turn conduit up at the building and at the source, the length of the conduit should not exceed 200 feet for secondary and 1000 feet for primary.
- (5) **Conduit bends.** Bends in addition to those at the building and the source should be avoided. If conditions make bends necessary, the overall length of secondary conduit should be reduced by 5 feet for each 10-degree increment of deflection beyond the two-90 degree bends at the ends. Primary conduit should be reduced by 25 feet for each 10-degree increment of deflection beyond the two-90 degree bends. Total secondary or primary conduit curvature shall not exceed 270 degrees. Horizontal bends will have a minimum 10-foot radius (use two-45 degree ells with conduit spacer).
- (6) **Manholes.** A manhole shall be installed when the overall conduit length approaches or exceeds the limits in (4) and (5) above.
- (7) **Public thoroughfare.** The Company will install the duct when an underground service source is located in a public thoroughfare.
- (8) **Service termination point.** Conduit installed by the contractor for DTE Electric furnished service conductors will terminate at an acceptable multiple service cabinet either on the outside wall of the building or immediately inside. From there, the customer's conductors will continue through or under the building to the service entrance equipment.

- (9) **Secondary service pedestal.** When the supply is from an underground distribution pedestal in an easement, the use of an all conduit installation is not advisable since conduit cannot be properly terminated at a pedestal.
- (10) **Entrance below grade.** If the service is designed to enter the building more than 6 inches below grade, careful consideration must be given to the possibility that water may enter the building through or around the conduit. The customer will be responsible for correcting such a condition. (See page 3-2-11.)
- (11) **Swimming Pools.** Underground wiring shall never be permitted under swimming pools. A minimum distance of 5 ft. shall exist between any underground supply conductor(s) and the inside wall of the pool in compliance with NEC Article 680.10 and NESC 351(C)(1). Where space limitations prevent wiring from being routed a distance of 5 ft or more from the pool, such wiring shall be permitted where installed in rigid metal conduit, intermediate metal conduit, or a nonmetallic sch 40 pvc.

## 8. Grounding.

Note: Any bond between the meter enclosure and joint users that interferes with removing the cover on the meter box is a violation of NEC 250.94 (3). The joint user who created the violation must correct the situation.

- (a) **Primary Conduit.** Primary metallic conduit will be grounded at the transformer with a bonding jumper connected between the conduit bushing and the transformer grounding connection. The conduit grounding bushing and the bonding jumper will be furnished and installed by the contractor.
- (b) **Metallic Sweeps.** Rigid steel or IMC sweeps protecting direct buried conductors, on the end of plastic duct, or on non-continuous conduit will be grounded as above.
- (c) **Secondary Conduit.** Secondary rigid or intermediate metal conduit that runs continuously to the building will not be grounded at the transformer since it will be grounded at the building per NEC requirements and this would cause a multiple ground path. Current taking an undesirable route on one of these multiple ground paths could cause problems such as conduit heating or tripping of the equipment ground-fault protection (GFPE).
- (d) **Transformers.** Transformer pad ground rod installation and connection are shown on pages 3-6-9 and 3-6-12.

## 9. Padmount Foundations.

- (a) **Specifications.** Drawings of concrete padmount foundations for DTE Electric transformers are shown on pages 3-6-1 to 3-6-6.
- (b) **Clearances.** Transformers must be located with proper clearances as shown on pages 3-7-11 through 3-7-12. The DTE Electric Planner must be consulted regarding pad location *before* construction begins.
- (c) **Guard Posts.** If the transformer is subject to vehicular traffic, the contractor must install guard posts as shown on page 3-6-10. The DTE Electric Planner must be consulted for the location of these posts.

**10. Direct Burial of Conductors.**

- (a) **Suitable Area.** Conductors will be direct buried only in those areas where conditions are suitable, such as open, no traffic locations. *Most commercial services must be in conduit.* Consult the DTE Electric Planner for exceptions.
- (b) **Primary Cable.** Primary commercial service conductors shall be direct buried only when specified by the Planning Area Leader.
- (c) **Conductor Location.** Underground electric service shall not be installed in the same trench with water pipes or sewer lines. It shall not be installed above anything that is at greater depth such as oil storage tanks or septic tanks. It shall not be installed parallel to recently constructed walls or footings in backfilled earth.
- (d) **Trench Depth.** The depth of the trench shall be measured from the existing top surface of ground or final grade, whichever is lower. (Cover is measured from the *top* of the cable or conductor to finished grade.)
- (e) **Trench Characteristics.** A trench carrying direct buried cable should be carefully finished on the bottom, smooth and even without sharp or rough projections that might injure the cable. The bottom of the trench shall be reasonably straight without abrupt changes in depth. Backfill shall be free of rubble and hard or frozen dirt.
- (f) **Fill Sand.** Well tamped fill sand shall be used as a bed and covering for direct buried cable where soil conditions such as stones, rocks, frozen chunks of earth, or other sharp objects are encountered.
- (g) **Joint Use.** When a telephone and electric service are in the same trench, the trench shall be a minimum of 4 inches wide and provide a minimum cover of 24 inches for secondary voltages and 30 inches for primary voltages.
- (h) **Conduit Required.** Conduit shall be used where cable is installed under a permanent surface, such as concrete driveways or walks, unexcavated crawl space under buildings, or under floors. This applies where pavement would have to be removed to repair or replace the cable.

**11. Cable Location.** See page 3-4-11 for service conductor placement on cable poles.

**12. Cable Pole Risers.** When conductors are furnished and installed by the customer, the contractor is responsible for providing mechanical protection for the cable up to 10 feet above grade on the cable pole. The Company will provide mechanical protection for DTE Electric owned and maintained conductors.

SECONDARY UNDERGROUND SERVICE  
Single Phase CL 200 UG

1-9-227

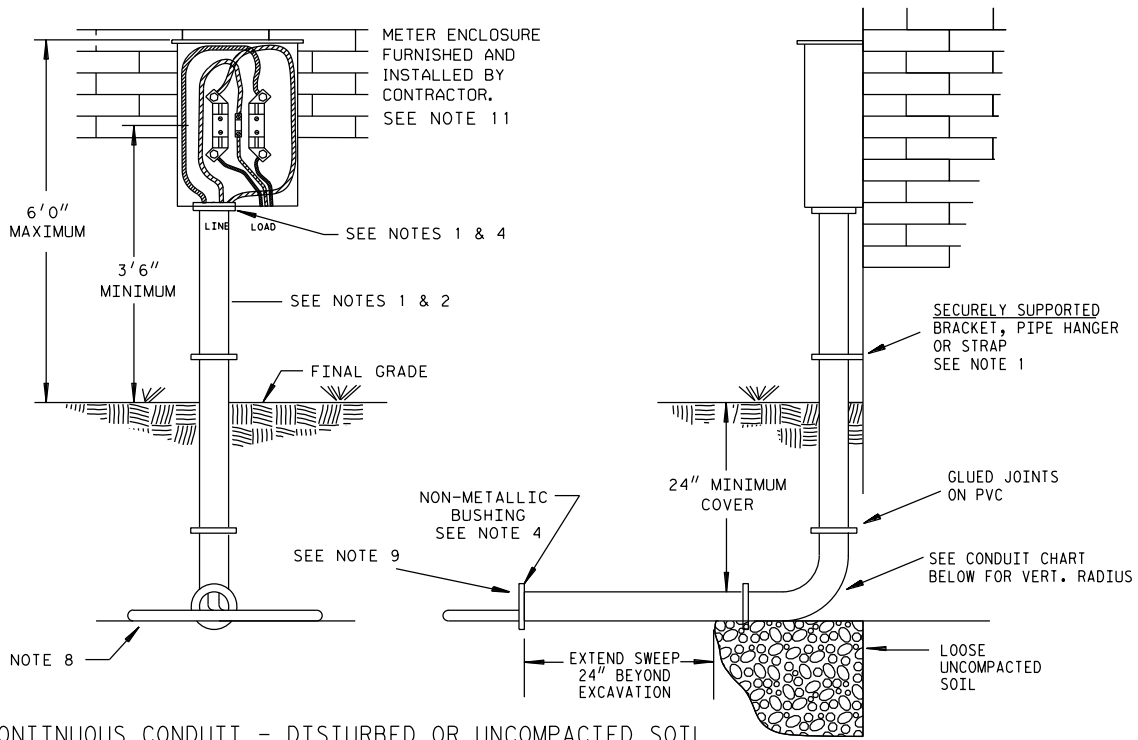

PROPER LINE CONDUCTOR TERMINATION

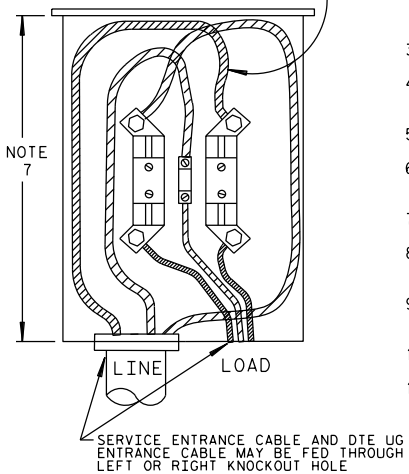

NOTES:

1. FURNISHED AND INSTALLED BY CONTRACTOR.
2. USE 2" CONDUIT FOR 3/0 RIGID GALVANIZED STEEL CONDUIT INTERMEDIATE METAL CONDUIT (IMC) NEMA TC-2 SCHEDULE 40 PVC
3. RISERS SHALL NOT BE CONCEALED OR RECESSED INTO BUILDING WALLS.
4. USE PLASTIC BUSHING OR INSULATED THROAT BUSHING. BOND PER N.E.C. ARTICLE 250. PVC CONDUIT WITH REAMED AND ROUNDED EDGES DOES NOT REQUIRE BOTTOM BUSHING.
5. SEE OTHER PAGES IN THIS SECTION FOR CABLE AND TRENCH SPECIFICATIONS.
6. OWNER MUST PROVIDE A ROUTE CLEAR OF TREES, LARGE STUMPS AND OBSTRUCTIONS WIDE ENOUGH TO ALLOW TRENCHING EQUIPMENT TO OPERATE.
7. SERVICE CABLES MUST BE TRAINED WITH AS MUCH SLACK AS POSSIBLE WITHIN THE BOX.
8. ANY FILL BENEATH THE CABLE TRENCH MUST BE AS SETTLED AND COMPACTED AS POSSIBLE. THE BACKFILL MUST BE FREE OF RUBBLE AND CLODS OF HARD OR FROZEN DIRT.
9. THE CONDUIT MUST INCLUDE A SWEEP THAT EXTENDS 24" BEYOND UNDISTURBED SOIL. THE BUILDER/ELECTRICIAN MUST MARK THE "BLIND SIDE" OF THE SWEEP.
10. GRADE MUST BE ±4" OF THE FINAL FINISHED GRADE
11. ANY BOND BETWEEN THE METER ENCLOSURE AND JOINT USERS THAT INTERFERES WITH REMOVING THE COVER ON THE METER BOX IS A VIOLATION OF NEC 250.94 (3). THE JOINT USER WHO CREATED THE VIOLATION MUST CORRECT THE SITUATION.

CONDUIT CHART

	CONDUIT LENGTH <15'	CONDUIT LENGTH >15'	
CONDUIT SIZE	VERT. RADIUS	VERT. RADIUS	HORIZ. RADIUS
2"	9 1/2"	36"	120"

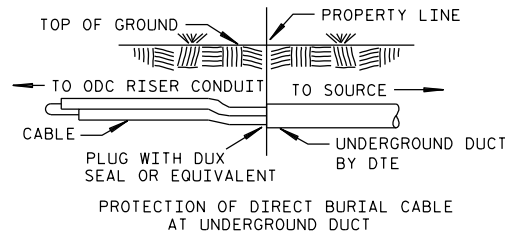

DTE ELECTRIC COMPANY ASSUMES NO RESPONSIBILITY FOR INJURY OR DAMAGE ARISING FROM THE USE OF THIS SPECIFICATION DIAGRAM.

SECONDARY UNDERGROUND SERVICE  
Single Phase CL 200 - 2 Position Horizontal

1-9-229.1

RESIDENTIAL ONLY - SEE NOTE 1 FOR USAGE

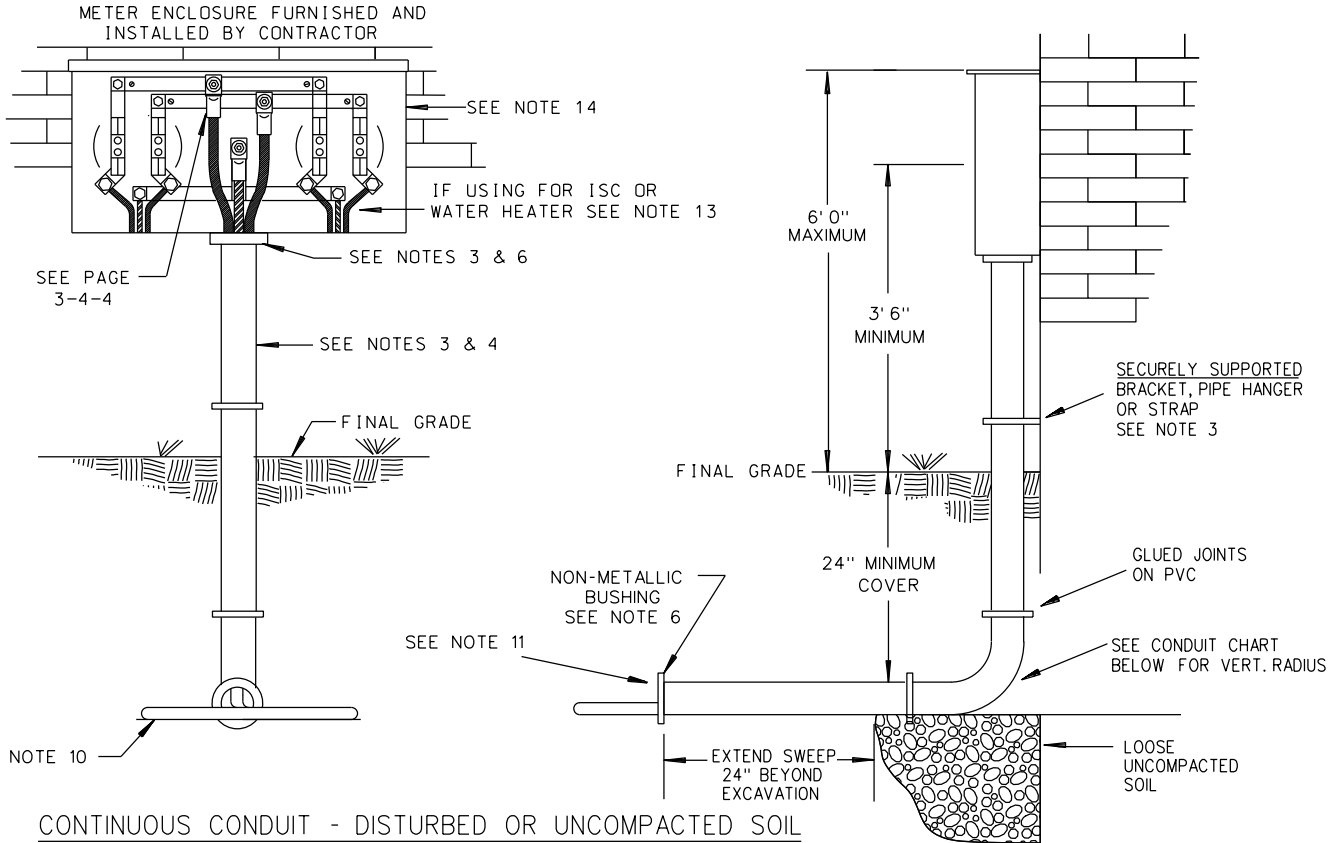

CONTINUOUS CONDUIT - DISTURBED OR UNCOMPACTED SOIL

NOTES:

1. THIS ENCLOSURE MAY BE USED TO ADD AN ISC, WATER HEATER ACCOUNT, EV OR GEOTHERMAL TO A SINGLE DWELLING. REFER TO PAGES 7-13-1 THROUGH 7-13-3 FOR DETAILED GEOTHERMAL SPECIFICATIONS
2. USED PRIMARILY AS A MINIMUM SERVICE FOR A GEOTHERMAL HEAT PUMP AND ASSOCIATED SYSTEMS
3. FURNISHED AND INSTALLED BY CONTRACTOR.
4. USE 2" FOR 3/0 AND 3" FOR 350 KCML DTE SERVICE (CONSULT PLANNER):  
RIGID GALVANIZED STEEL CONDUIT  
INTERMEDIATE METAL CONDUIT (IMC)  
NEMA TC-2 SCHEDULE 40 PVC
5. RISERS SHALL NOT BE CONCEALED OR RECESSED INTO BUILDING WALLS.
6. USE NONMETALLIC OR INSULATED THROAT BUSHING. BOND PER N.E.C. ARTICLE 250.  
PVC CONDUIT WITH REAMED AND ROUNDED EDGES DOES NOT REQUIRE BOTTOM BUSHING.
7. 3' 6" MINIMUM HEIGHT FROM CENTER OF METER FACE TO FINAL GRADE
8. SEE OTHER PAGES IN THIS SECTION FOR CABLE AND TRENCH SPECIFICATIONS.
9. OWNER MUST PROVIDE A ROUTE CLEAR OF TREES, LARGE STUMPS AND OBSTRUCTIONS WIDE ENOUGH TO ALLOW TRENCHING EQUIPMENT TO OPERATE.
10. ANY FILL BENEATH THE CABLE TRENCH MUST BE AS SETTLED AND COMPACTED AS POSSIBLE. THE BACKFILL MUST BE FREE OF RUBBLE AND CLODS OF HARD OR FROZEN DIRT.
11. THE CONDUIT MUST INCLUDE A SWEEP THAT EXTENDS 24" PAST THE UNDISTURBED SOIL. THE BUILDER/ELECTRICIAN MUST MARK THE "BLIND SIDE" OF THE SWEEP
12. GRADE MUST BE ±4" OF THE FINAL FINISHED GRADE
13. IN THE EVENT THE CUSTOMER NO LONGER WISHES TO USE THE ISC OR WATER HEATER RATE, THE CUSTOMER IS RESPONSIBLE FOR HAVING THE ISC OR WATER HEATER SERVICE WIRES REROUTED TO THE LOAD SIDE OF THE GENERAL SERVICE.
- ➔ 14. ANY BOND BETWEEN THE METER ENCLOSURE AND JOINT USERS THAT INTERFERES WITH REMOVING THE COVER ON THE METER BOX IS A VIOLATION OF NEC 250.94 (3). THE JOINT USER WHO CREATED THE VIOLATION MUST CORRECT THE SITUATION.

CONDUIT CHART			
	CONDUIT LENGTH <15'	CONDUIT LENGTH ≥15'	
CONDUIT SIZE	VERT. RADIUS	VERT. RADIUS	HORIZ. RADIUS
2"	9 1/2"	36"	120"
3"	13"	36"	120"
4"	36"	36"	120"

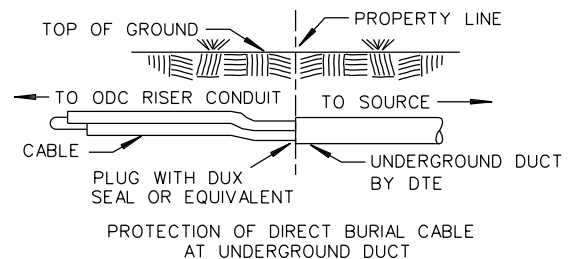

DTE ELECTRIC COMPANY ASSUMES NO RESPONSIBILITY FOR INJURY OR DAMAGE ARISING FROM THE USE OF THIS SPECIFICATION DIAGRAM.



SECONDARY UNDERGROUND SERVICE  
Single Phase CL 320 UG

1-9-229.2

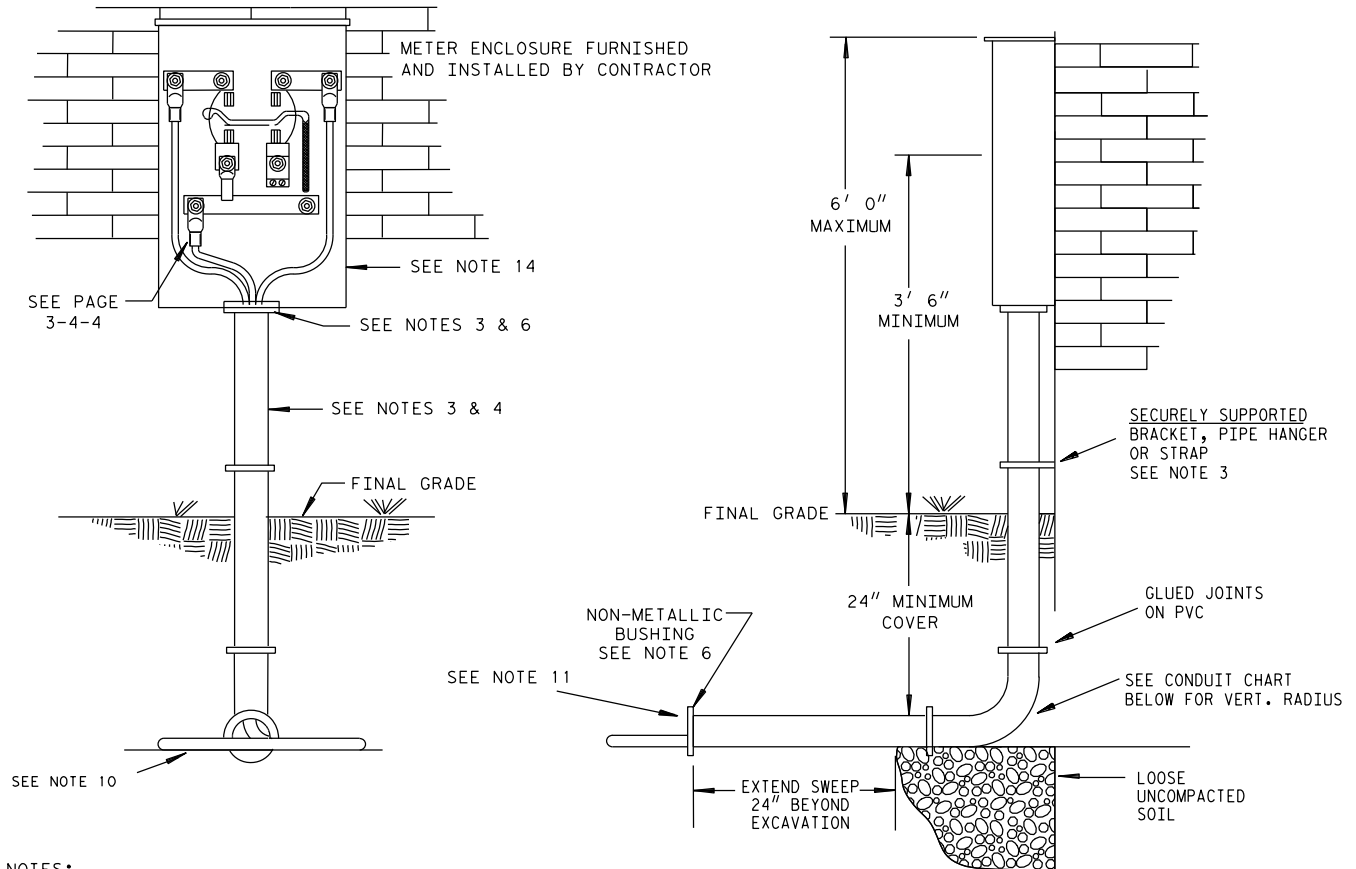

NOTES:

1. THIS ENCLOSURE IS RATED FOR 320 CONNECTED LOAD (CONSULT PLANNER).
2. THIS ENCLOSURE HAS LINE SIDE TAP CONNECTIONS FOR ADDING AN APPROVED METER FOR A WATER HEATER OR ISC ACCOUNT.
3. FURNISHED AND INSTALLED BY CONTRACTOR.
4. USE 3" FOR 350 KCMIL DTE SERVICE (CONSULT PLANNER):  
RIGID GALVANIZED STEEL CONDUIT  
INTERMEDIATE METAL CONDUIT (IMC)  
NEMA TC-2 SCHEDULE 40 PVC
5. RISERS SHALL NOT BE CONCEALED OR RECESSED INTO BUILDING WALLS.
6. USE NONMETALLIC OR INSULATED THROAT BUSHING. BOND PER N.E.C. ARTICLE 250.  
PVC CONDUIT WITH REAMED AND ROUNDED EDGES DOES NOT REQUIRE BOTTOM BUSHING.
7. 3'6" MINIMUM HEIGHT FROM CENTER OF METER FACE TO FINAL GRADE
8. SEE OTHER PAGES IN THIS SECTION FOR CABLE AND TRENCH SPECIFICATIONS.
9. OWNER MUST PROVIDE A ROUTE CLEAR OF TREES, LARGE STUMPS AND OBSTRUCTIONS WIDE ENOUGH TO ALLOW TRENCHING EQUIPMENT TO OPERATE.
10. ANY FILL BENEATH THE CABLE TRENCH MUST BE AS SETTLED AND COMPACTED AS POSSIBLE. THE BACKFILL MUST BE FREE OF RUBBLE AND CLODS OF HARD OR FROZEN DIRT.
11. THE CONDUIT MUST INCLUDE A SWEEP THAT EXTENDS 24" BEYOND THE UNDISTURBED SOIL. THE BUILDER/ELECTRICIAN MUST MARK THE "BLIND SIDE" OF THE SWEEP.
12. GRADE MUST BE 4" OF THE FINAL FINISHED GRADE.
13. 36" CONDUIT MAY BE USED WITH UNDERGROUND EQUIPMENT PERFORMANCE APPROVAL.
14. ANY BOND BETWEEN THE METER ENCLOSURE AND JOINT USERS THAT INTERFERES WITH REMOVING THE COVER ON THE METER BOX IS A VIOLATION OF NEC 250.94 (3). THE JOINT USER WHO CREATED THE VIOLATION MUST CORRECT THE SITUATION.

CONDUIT CHART

CONDUIT SIZE	CONDUIT LENGTH <15'		HORIZ. RADIUS
	VERT. RADIUS	VERT. RADIUS	
2"	9 1/2"	36"	120"
3"	13" SEE NOTE 13	36"	120"
4"	36"	36"	120"

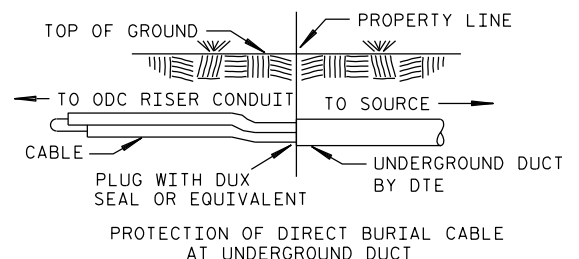

DTE ELECTRIC COMPANY ASSUMES NO RESPONSIBILITY FOR INJURY OR DAMAGE ARISING FROM THE USE OF THIS SPECIFICATION DIAGRAM.

TERMINAL ASSEMBLY  
DTE ELECTRIC LINE CREW

1-9-230

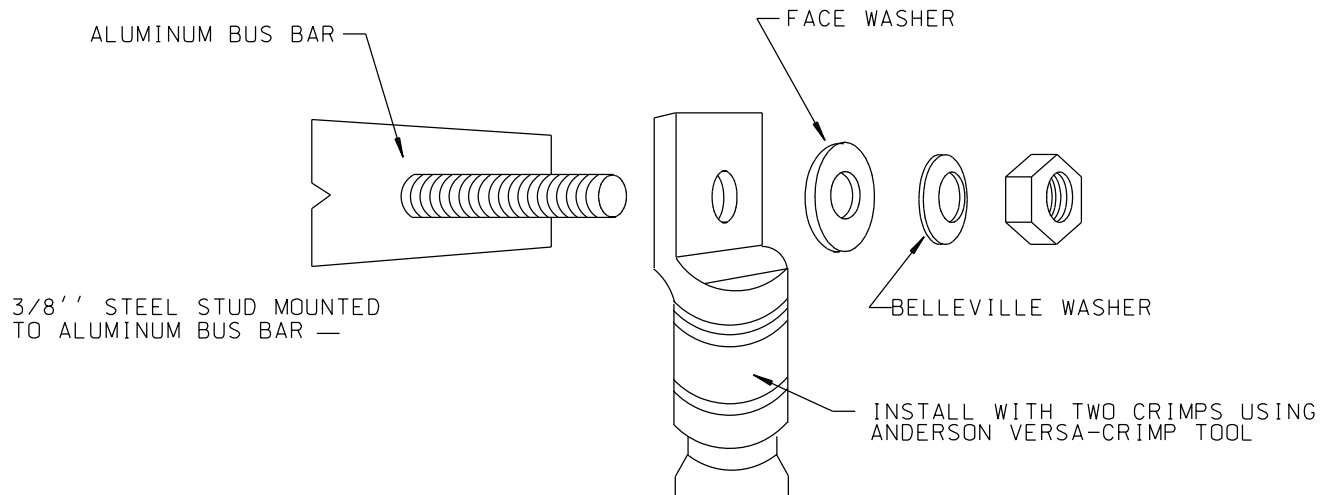
NOTES:

1. MATERIALS ABOVE ARE FURNISHED AND INSTALLED BY DTE ELECTRIC.
2. THESE ARE THE ONLY TERMINALS ACCEPTABLE FOR TERMINATING LINE SIDE CONDUCTORS IN THE SINGLE PHASE CL 320 AND CL 200 - 2 POS HORIZONTAL ENCLOSURES

## FOR 350 kcmil DTE SERVICES:

USE ALUMINUM TERMINAL ED. NO. 721-1301

FOR 4/0 NEUTRAL USE ALUMINUM TERMINAL ED. NO. 721-1302

## FOR 3/0 AWG DTE SERVICES:

USE ALUMINUM TERMINAL ED. NO. 721-1302

FOR 1/0 NEUTRAL USE ALUMINUM TERMINAL ED. NO. 721-1682

DTE ELECTRIC COMPANY ASSUMES NO RESPONSIBILITY FOR INJURY OR DAMAGE ARISING FROM THE USE OF THIS SPECIFICATION DIAGRAM.

SECONDARY UNDERGROUND SERVICE FROM OVERHEAD DISTRIBUTION ON STEEL POLES OR NON-TRUCK ACCESSIBLE WOOD POLES CABLE SIZE UP TO 350 KCMIL AL

NOTES:

1. WHEN FIELD CONDITIONS INDICATE THAT NOT MORE THAN ONE SERVICE IS POSSIBLE, THEN NO SERVICE PEDESTAL IS REQUIRED. USE DETAIL 984, 986 OR 988 SIM-ESIG PAGES 3-4-7 OR 3-4-8.
2. WHEN MORE THAN ONE SERVICE IS PROVIDED, A SERVICE PEDESTAL IS REQUIRED. PEDESTAL IS CAPABLE OF ACCOMMODATING UP TO FIVE SERVICES.
3. SNAKE CABLE IN TRENCH TO COMPENSATE FOR DISTURBED EARTH SETTLING. SEE PLAN DETAIL. FOR 100% CONDUIT PLEASE REFER TO 1-9-227 THE SWEEP REQUIREMENTS
4. NO OTHER RIGHT-OF-WAY WILL BE REQUIRED IF THIS IS A PUBLIC UTILITY EASEMENT AND THE PEDESTAL, FEED CABLES AND THE SERVICE LATERALS FOR OTHER LOTS WILL BE KEPT IN THE EASEMENT. SECURE RECORDED EASEMENT FOR ANY OTHER CONDITIONS.
5. SUITABLE FOR JOINT USE.
6. INSTALL DUCT SEAL TO SEAL THE CABLES. IF CUSTOMER RUNS 100% CONDUIT, INSTALL SWEEP. SWEEP SHALL PROTRUDE 4 TO 12 INCHES ABOVE FINAL GRADE.
7. TO INSTALL BRACKET USE ONE 5/8" BOLT FOR TOP MOUNTING HOLE AND 1/2" LAG FOR THE BOTTOM HOLE. USE ONE 5/8" BOLT FOR TOP HOLE AND BANDING FOR BOTTOM BRACKET HOLE TO MOUNT ON STEEL POLES. MINIMUM CLASS 4 POLE SIZE REQUIRED FOR CABLE STANDOFF BRACKETS. ACTUAL POLE SIZE SHOULD BE DETERMINED BY PLANNER.
8. ANY BOND BETWEEN THE METER ENCLOSURE AND JOINT USERS THAT INTERFERES WITH REMOVING THE COVER ON THE METER BOX IS A VIOLATION OF NEC 250.94 (3). THE JOINT USER WHO CREATED THE VIOLATION MUST CORRECT THE SITUATION.
9. ON WOOD POLES, DETAIL SHALL ONLY BE BUILT IN NON-TRUCK ACCESSIBLE LOCATIONS.
10. CABLE STANDOFF SHALL BE USED FOR ALL SECONDARY CABLE ON STEEL POLES.
11. DETAIL SHALL ONLY BE USED FOR CABLE SIZES UP TO AND INCLUDING 350 KCMIL AL.

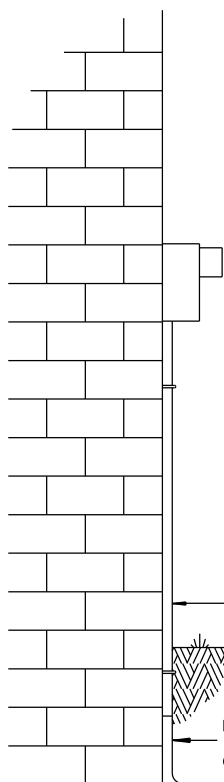

SEE NOTE 3

SERVICE CABLE TO METER 3/0 AL MINIMUM SEE PAGES 3-1-8 THRU 3-2-11 FOR POLICY

SERVICE PLANNING TO DETERMINE FUSE SIZE FOR OVERHEAD TAP. SEE 1-9-84 FOR TAPPING. SEE SIM-ESIG PAGES-12-4-5 AND 12-4-6.

CABLE GRIPS NOT REQUIRED

CABLE STANDOFF BRACKET SEE 1-24-7.13

SEE 1-9-231 FOR DETAILS OF CONNECTIONS TO PEDESTAL

3' MIN.

FINAL GRADE

NOTE 6

12" MIN.

12" MIN. STRAIGHT DISTANCE

SEE NOTE 3

SECONDARY CABLE

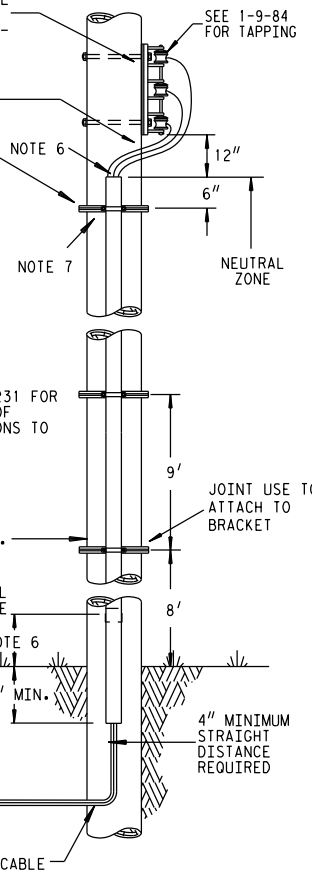

DETAIL 971

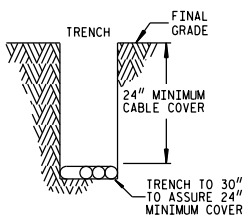

SECTION DETAIL

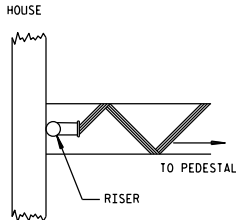

PLAN DETAIL

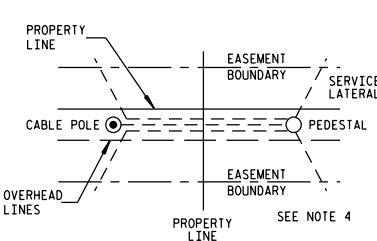

PROPERTY LINE

SEE NOTE 4

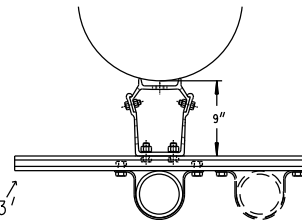

PEDESTAL

DTE ELECTRIC COMPANY ASSUMES NO RESPONSIBILITY FOR INJURY OR DAMAGE ARISING FROM THE USE OF THIS SPECIFICATION DIAGRAM.

SECONDARY UNDERGROUND SERVICE ON TRUCK ACCESSIBLE WOOD POLE ONLY FROM OVERHEAD DISTRIBUTION

1. WHEN FIELD CONDITIONS INDICATE THAT NOT MORE THAN ONE SERVICE IS POSSIBLE, THEN NO SERVICE PEDESTAL IS REQUIRED. USE DETAIL 984, 986 OR 988 SIM-ESIG PAGES 3-4-7 OR 3-4-8.
2. WHEN MORE THAN ONE SERVICE IS PROVIDED, A SERVICE PEDESTAL IS REQUIRED. PEDESTAL IS CAPABLE OF ACCOMMODATING UP TO FIVE SERVICES.
3. SNAKE CABLE IN TRENCH TO COMPENSATE FOR DISTURBED EARTH SETTLING. SEE PLAN DETAIL.
4. NO OTHER RIGHT-OF-WAY WILL BE REQUIRED IF THIS IS A PUBLIC UTILITY EASEMENT AND THE PEDESTAL, FEED CABLES AND THE SERVICE LATERALS FOR OTHER LOTS WILL BE KEPT IN THE EASEMENT. SECURE RECORDED EASEMENT FOR ANY OTHER CONDITIONS.
5. SUITABLE FOR JOINT USE.
6. ANY BOND BETWEEN THE METER ENCLOSURE AND JOINT USERS THAT INTERFERES WITH REMOVING THE COVER ON THE METER BOX IS A VIOLATION OF NEC 250.94 (3). THE JOINT USER WHO CREATED THE VIOLATION MUST CORRECT THE SITUATION.
7. DETAIL TO BE USED AT TRUCK ACCESSIBLE LOCATIONS FOR WOOD POLES ONLY.
8. DETAIL NOT TO BE USED AT STEEL POLE LOCATIONS. REFER TO DETAIL 971.

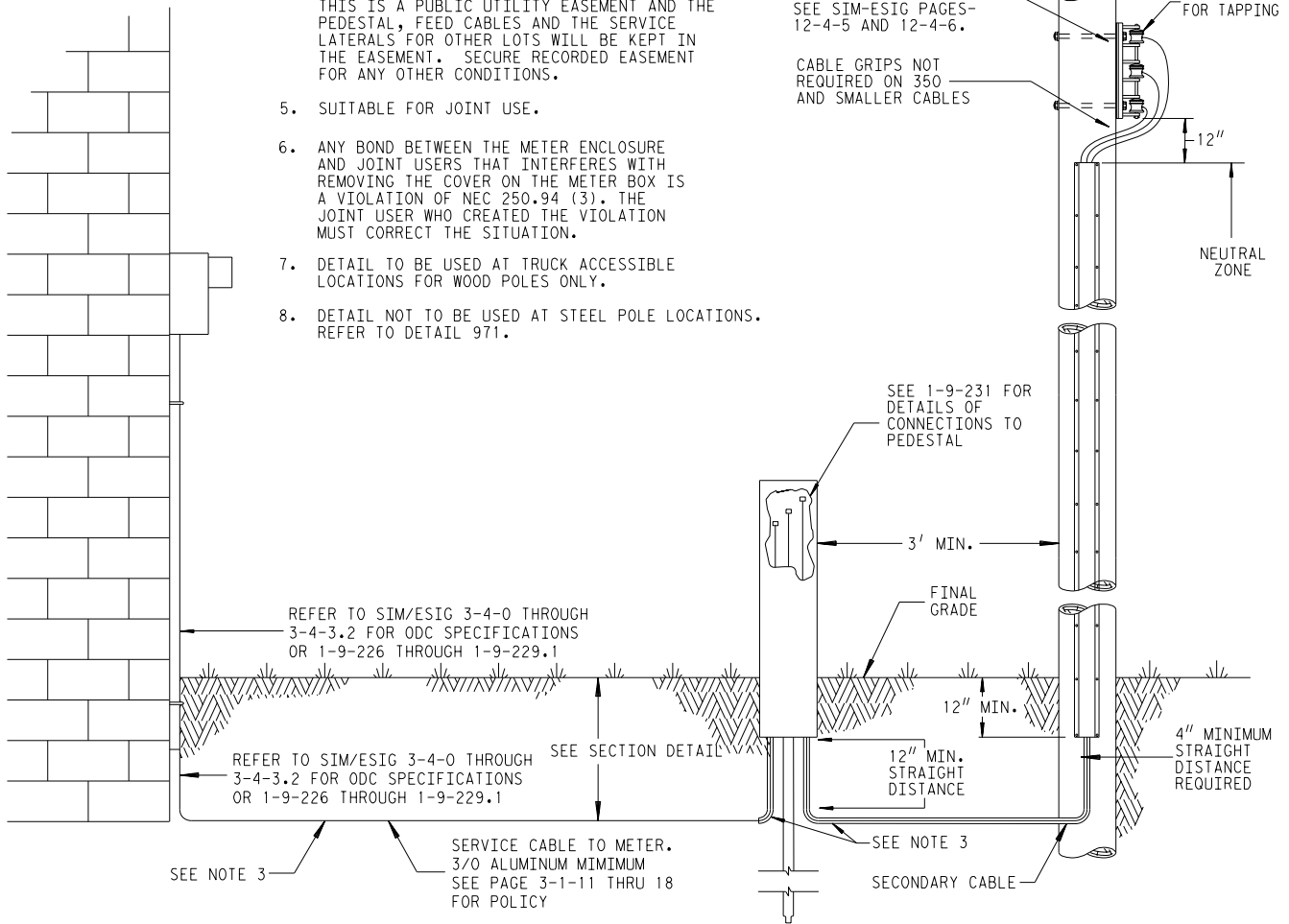

DETAIL 971A

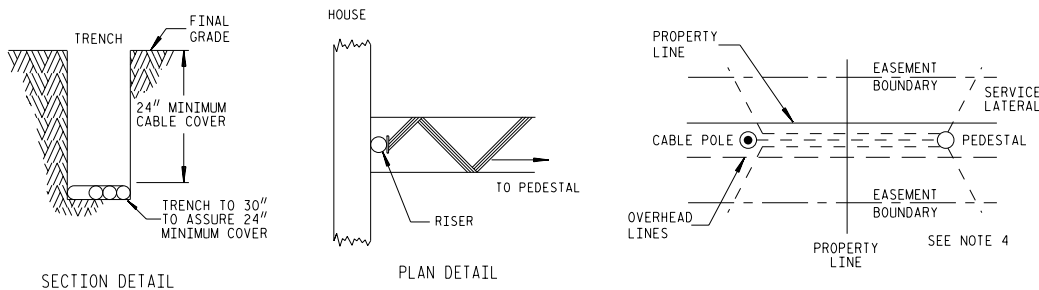

DTE ELECTRIC COMPANY ASSUMES NO RESPONSIBILITY FOR INJURY OR DAMAGE ARISING FROM THE USE OF THIS SPECIFICATION DIAGRAM.

POST MOUNTED UNDERGROUND SERVICE  
 100-320 AMP SINGLE PHASE OR 100 TO 200 AMP THREE PHASE  
 USED FOR INDIVIDUAL MOBILE HOMES, SEWER LIFT STATIONS,  
 FARMS OR ANY LOCATION THAT REQUIRES A REMOTE METER

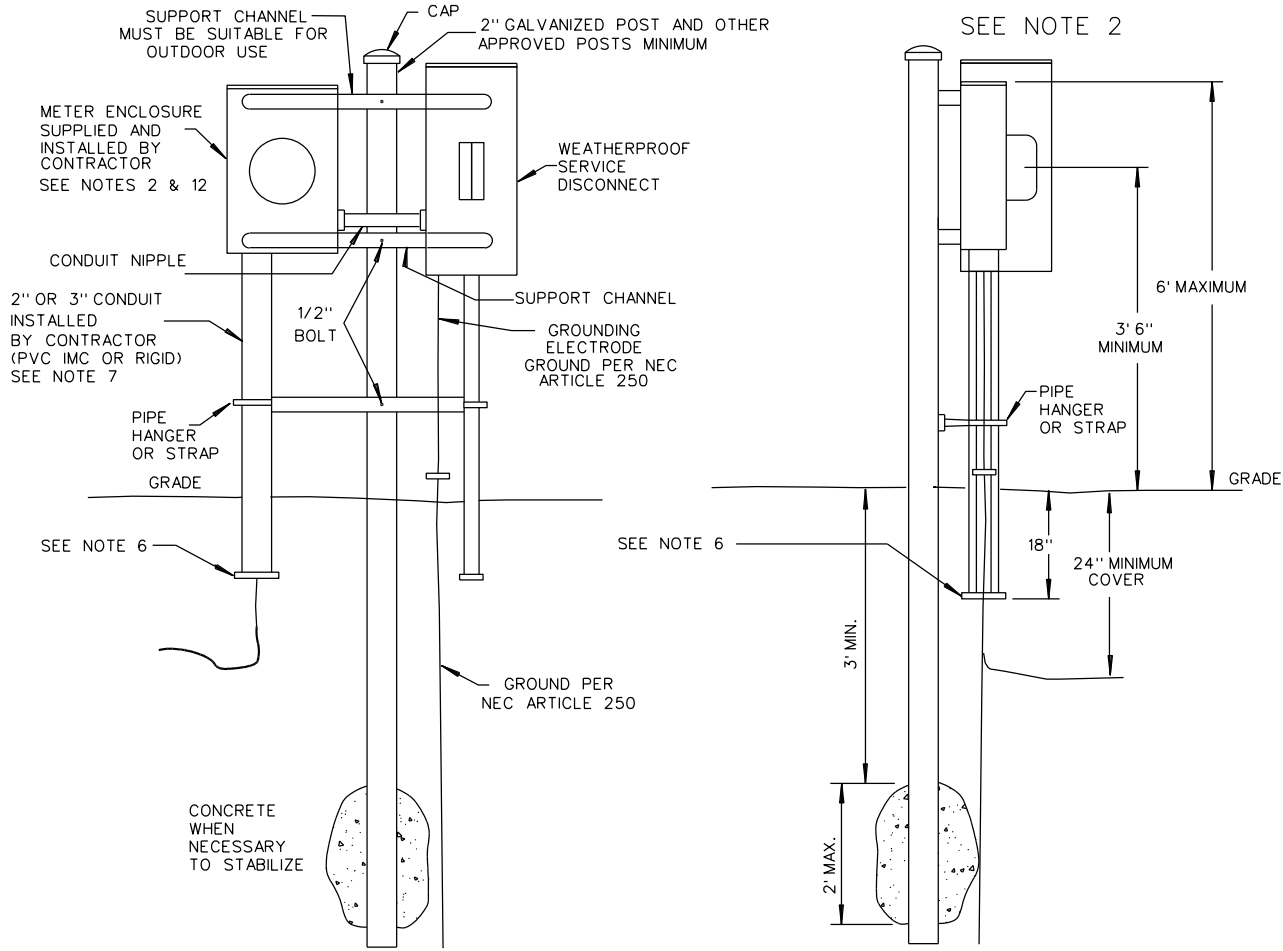

NOTES:

1. ALL POST MOUNTED SERVICE EQUIPMENT IS OWNED AND MAINTAINED BY THE CUSTOMER.
2. METER BOX MAY BE:
  - 1 PH CL 200 FOR 100 TO 200 AMP SINGLE PHASE
  - 1 PH CL 320 FOR 200 TO 320 AMP SINGLE PHASE
  - 3 PH CL 200 FOR 100 TO 200 AMP THREE PHASE
3. 3' 6" MINIMUM HEIGHT TO CENTER OF METER FACE FROM GRADE AND 6' MAXIMUM TO TOP OF METER BOX.
4. USE 2" RIGID PIPE POST WITH CAP. WOOD POSTS ARE NOT ALLOWED. THE POST MUST BE INSTALLED PLUMB AND REMAIN PLUMB AT ALL TIMES.
5. SERVICE DISCONNECT AND RACEWAYS MUST BE RAIN-TIGHT. THE DISCONNECT IS SIZED, FURNISHED AND INSTALLED BY CUSTOMER.
6. SUPPORT CHANNEL OR ANGLE IRON SHOULD BE BOLTED TO POST WITH 1/2" BOLTS AND WASHERS OR 3/8" U-BOLTS OR PIPE HANGER CLAMPS DESIGNED FOR THAT USE.
7. RIGID AND IMC CONDUIT REQUIRE NONMETALLIC BUSHINGS WITH BONDING PER N.E.C. 250. PVC CONDUIT MUST BE TRIMMED TO REMOVE SHARP EDGES.
8. DTE ELECTRIC INSTALLED UG SERVICES REQUIRE 2" CONDUIT FOR 3/0 SINGLE PHASE SERVICE AND 3" CONDUIT FOR THREE PHASE 3/0 SERVICES.
9. A SYSTEM GROUNDING ELECTRODE MUST BE INSTALLED IN COMPLIANCE WITH N.E.C. 250.
10. ADDRESS MUST BE PERMANENTLY MARKED ON METER ENCLOSURE. USE PERMANENT LETTERS OR STICKERS.
11. THE POST MOUNT SHOULD BE INSTALLED CLOSE TO THE SOURCE POLE OR PAD MOUNT TRANSFORMER. IF A POLE DOES NOT EXIST ON PROPERTY, THE POST MOUNT SHOULD BE IN ONE OF REAR CORNERS OF THE PROPERTY (EITHER OPTION MUST BE OUTSIDE OF DTE EASEMENT). ALL LOCATIONS MUST BE CLEAR OF DEBRIS OR BUSHES AND EASE OF ACCESS.
12. THE USE OF POST MOUNT MUST BE APPROVED BY LOCAL BUILDING INSPECTOR.
12. ANY BOND BETWEEN THE METER ENCLOSURE AND JOINT USERS THAT INTERFERES WITH REMOVING THE COVER ON THE METER BOX IS A VIOLATION OF NEC 250.94 (3). THE JOINT USER WHO CREATED THE VIOLATION MUST CORRECT THE SITUATION.

REFERENCE PAGE
5-3-5
5-3-6
5-3-18 & 19

DTE ELECTRIC COMPANY ASSUMES NO RESPONSIBILITY FOR INJURY OR DAMAGE ARISING FROM THE USE OF THIS SPECIFICATION DIAGRAM.

FIBERGLASS PEDESTAL MOUNTED UNDERGROUND SERVICE  
 200 AMP SINGLE PHASE OR THREE PHASE  
 USED FOR INDIVIDUAL MOBILE HOMES, SEWER LIFT STATIONS,  
 FARMS OR ANY LOCATION THAT REQUIRES A REMOTE METER

ACCEPTABLE DTE ELECTRIC  
 200 AMP SINGLE POINT  
 METER ENCLOSURE. RATED  
 AT 200 AMPS LISTED IN  
 SIM/ESIG SECTION 5-8.  
 INSTALLED BY CUSTOMER.  
 SEE NOTE 9

2" SCHEDULE 80 ELECTRIC  
 GRADE PVC VERTICAL RISER  
 WITH CONDUIT CLAMP(S).  
 REFER TO SIM/ESIG 3-4-1

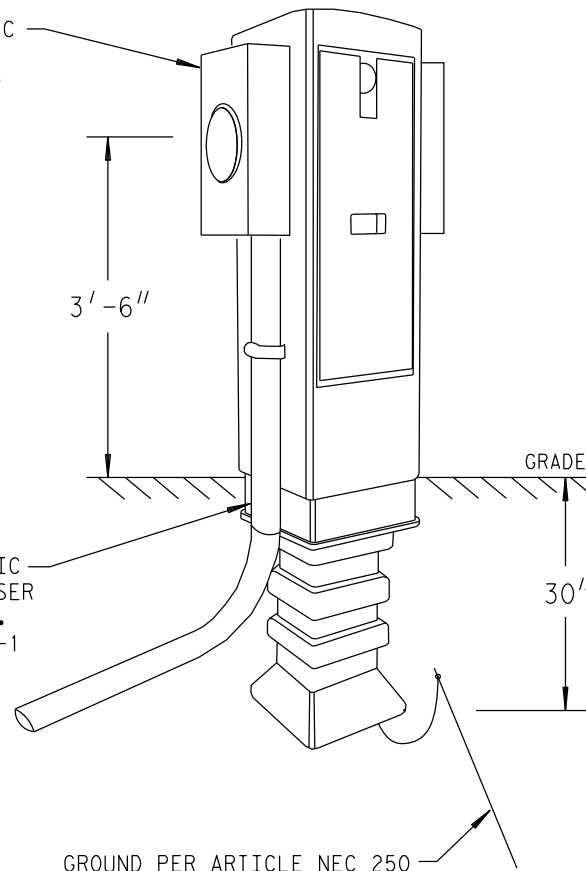

**NOTES:**

1. NORDIC MPP-141480-MGX PEDESTAL. BURIED 30" DEEP WITH 50" STANDING ABOVE GRADE. ATTACH 200 AMP METER ENCLOSURE TO PEDESTAL MAINTAINING MINIMUM 3'-6" ABOVE GRADE. PEDESTAL AND METER TO BE INSTALLED BY CUSTOMER. REFER TO SIM/ESIG PAGES 3-4-6 AND 3-14-22 FOR ALTERNATE REMOTE MOUNTING SPECIFICATIONS.
2. CONDUIT INSTALLED ON OUTSIDE FASTENED TO PEDESTAL WITH A CONDUIT CLAMP(S) (CONDUIT TO BE CONTINUOUS TO SOURCE FEED POINT). USE ONLY DTE ELECTRIC APPROVED SINGLE POSITION METER ENCLOSURE RATED FOR 200A UG LISTED IN SIM/ESIG SECTION 5-8. USE ONLY PRE-MANUFACTURED KNOCKOUT AT BACK OF METER ENCLOSURE TO WIRE TO DISCONNECT.
3. SERVICE DISCONNECT MUST BE RAINTIGHT. THE DISCONNECT IS SIZED, FURNISHED AND INSTALLED BY CUSTOMER.
4. RIGID AND IMC CONDUIT REQUIRE NON-METALLIC BUSHINGS WITH BONDING PER NEC 250. PVC CONDUIT MUST BE TRIMMED TO REMOVE SHARP EDGES.
5. DTE ELECTRIC INSTALLED UG SERVICES REQUIRE 2" CONDUIT FOR 3/O SINGLE PHASE SERVICE AND 3" CONDUIT FOR 3/O THREE PHASE SERVICE.
6. A SYSTEM GROUNDING ELECTRODE MUST BE INSTALLED IN COMPLIANCE WITH NEC 250.
7. ADDRESS MUST BE PERMANENTLY MARKED ON METER ENCLOSURE. USE PERMANENT LETTERS OR STICKERS.
8. THE USE OF THIS PEDESTAL MUST BE APPROVED BY LOCAL BUILDING/ELECTRICAL INSPECTOR.
9. ANY BOND BETWEEN THE METER ENCLOSURE AND JOINT USERS THAT INTERFERES WITH REMOVING THE COVER ON THE METER BOX IS A VIOLATION OF NEC 250.94 (3). THE JOINT USER WHO CREATED THE VIOLATION MUST CORRECT THE SITUATION.

DTE ELECTRIC COMPANY ASSUMES NO RESPONSIBILITY FOR INJURY  
 OR DAMAGE ARISING FROM THE USE OF THIS SPECIFICATION DIAGRAM.

1-9-84

SECONDARY UNDERGROUND SERVICE INSTALLATION  
ON STEEL POLE OR NON-TRUCK ACCESSIBLE WOOD POLE  
FOR CABLE SIZES UP TO 350 KCMIL ALUMINUM

USE OF THIS DETAIL DEPENDS ON CONDITIONS IN NOTES  
120/240 V 120/208Y V 277/480Y V

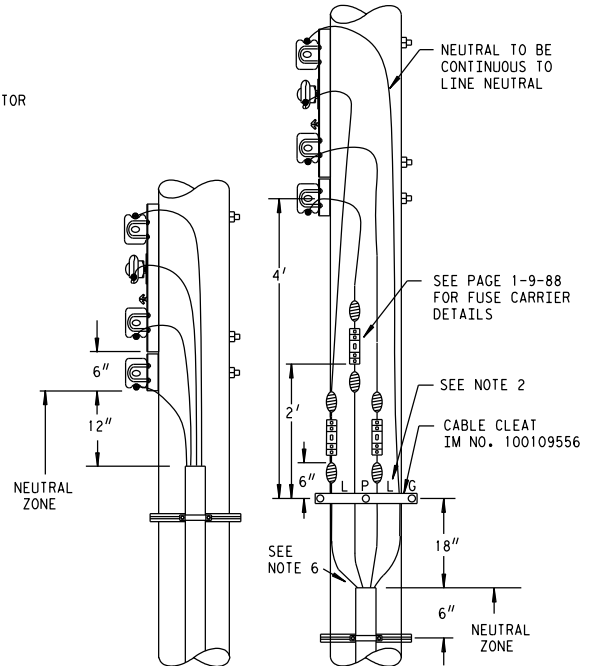
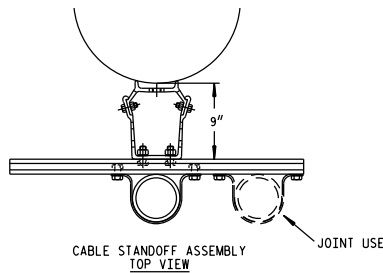
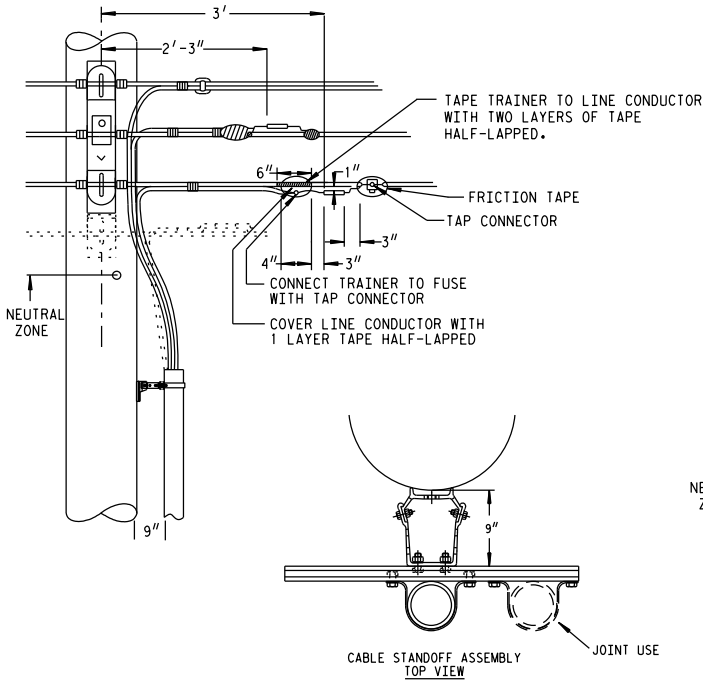

NOTES:

1. SERVICE PLANNER DETERMINES DTE FUSE REQUIREMENTS ON POLE. PER SIM PAGE 12-4-5 & 12-4-6.
2. FOR CONDUCTOR IDENTIFICATION AND POLE QUADRANT ASSIGNMENT - SEE UG PAGE 1-9-93 (SIM-ESIG 3-4-11).
3. STEEL U-GUARD SHALL BE GROUNDED BY INSTALLER IN ACCORDANCE WITH NEC 230 & 250. THEY MAY BE GROUNDED TO DTE GROUNDING. SEE UG PAGE 1-24-621 FOR STEEL U-GUARD. IF UG CONDUIT IS STEEL AND CONTINUOUS TO THE BUILDING, DO NOT GROUND AT THE POLE. STEEL U-GUARD SHALL BE USED IN AREA WHERE VEHICLES HAVE ACCESS. OTHERWISE, PLASTIC U-GUARD SHALL BE USED.
4. MINIMUM NO. 2 SIZE POWER AND NEUTRAL CONDUCTOR. SERVICE PLANNER MUST APPROVE SIZE AND INSULATION. SEE SIM-ESIG 3-3-1.
5. WHEN MORE THAN ONE SERVICE IS PROVIDED, A SERVICE PEDESTAL IS REQUIRED. IT IS CAPABLE OF ACCOMMODATING FIVE SERVICES. SEE UG PAGE 1-9-71 (SIM-ESIG 3-4-5).
6. USE DUCT SEAL TO SEAL CABLES AT TOP OF CONDUIT. IF CUSTOMER RUNS 100% CONDUIT, INSTALL SWEEP. SWEEP SHALL PROTRUDE 4 TO 12 INCHES ABOVE FINAL GRADE.
7. TO INSTALL BRACKET USE ONE 5/8" BOLT FOR TOP MOUNTING HOLE AND 1/2" LAG FOR THE BOTTOM HOLE. FOR STEEL POLES, USE ONE 5/8" BOLT FOR TOP HOLE AND BANDING FOR BOTTOM BRACKET HOLE. MINIMUM CLASS 4 POLE SIZE REQUIRED FOR CABLE STANDOFF ASSEMBLY. ACTUAL POLE SIZE SHALL BE DETERMINED BY PLANNER.
8. ON WOOD POLES, DETAIL SHALL ONLY BE BUILT IN NON-TRUCK ACCESSIBLE LOCATIONS.
9. CABLE STANDOFF SHALL BE USED FOR ALL SECONDARY CABLE ON STEEL POLES.
10. DETAIL TO BE USED ONLY FOR CABLE SIZES UP TO AND INCLUDING 350 KCMIL AL.

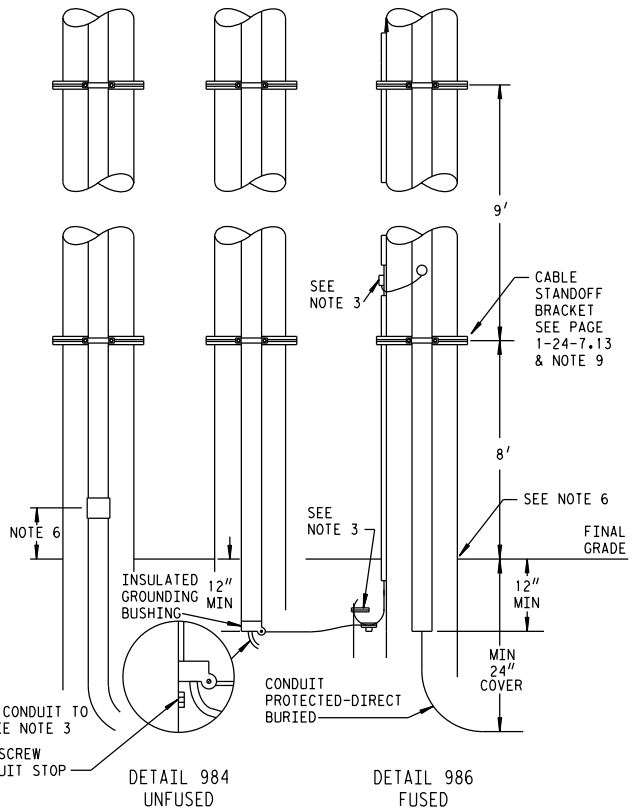

DTE ELECTRIC COMPANY ASSUMES NO RESPONSIBILITY FOR INJURY OR DAMAGE ARISING FROM THE USE OF THIS SPECIFICATION DIAGRAM.

SECONDARY UNDERGROUND SERVICE INSTALLATION  
ON TRUCK ACCESSIBLE WOOD POLE ONLY  
FOR CABLE SIZES UP TO 750 KCMIL

1-9-84.1

USE OF THIS DETAIL DEPENDS ON CONDITIONS IN NOTES  
120/240 V 120/208Y V 277/480Y V

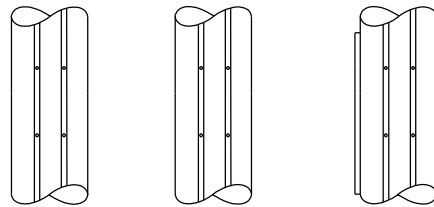
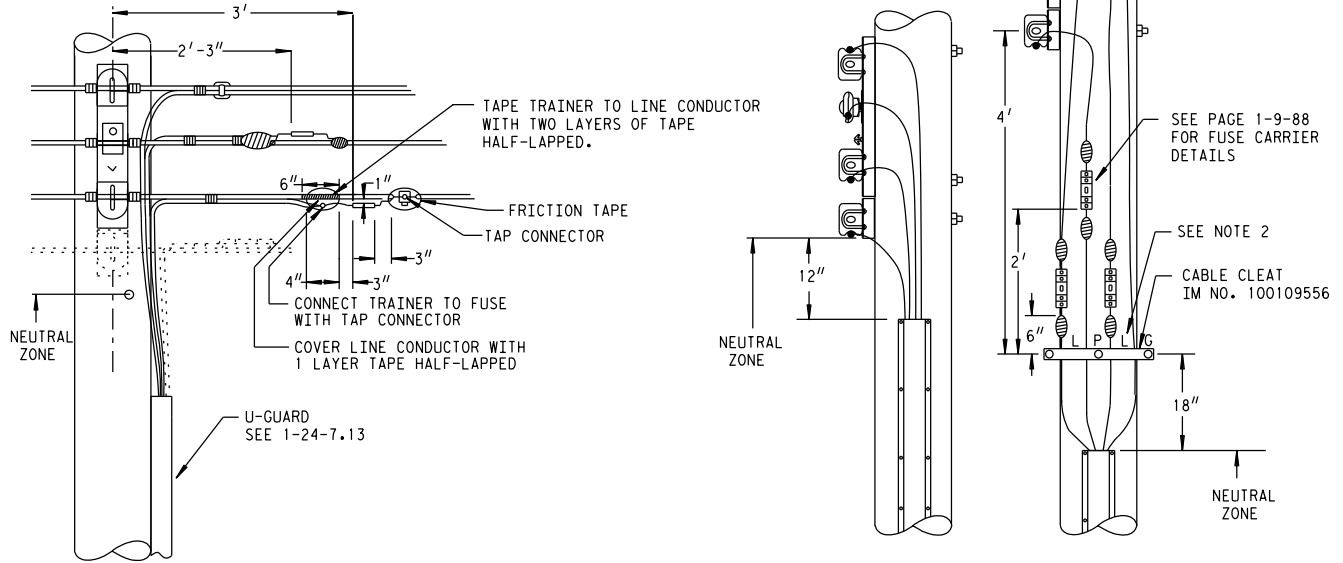

NOTES:

1. SERVICE PLANNER DETERMINES DTE FUSE REQUIREMENTS ON POLE PER SIM PAGE 12-4-5 & 12-4-6.
2. FOR CONDUCTOR IDENTIFICATION AND POLE QUADRANT ASSIGNMENT - SEE UG PAGE 1-9-93 (SIM-ESIG 3-4-11).
3. STEEL U-GUARD SHALL BE GROUNDED BY INSTALLER IN ACCORDANCE WITH NEC 230 & 250. THEY MAY BE GROUNDED TO DTE GROUNDING. SEE UG PAGE 1-24-621 FOR STEEL U-GUARD. IF UG CONDUIT IS STEEL AND CONTINUOUS TO THE BUILDING, DO NOT GROUND AT THE POLE. STEEL U-GUARD SHALL BE USED IN AREA WHERE VEHICLES HAVE ACCESS. OTHERWISE, PLASTIC U-GUARD SHALL BE USED.
4. MINIMUM NO. 2 SIZE POWER AND NEUTRAL CONDUCTOR. SERVICE PLANNER MUST APPROVE SIZE AND INSULATION. SEE SIM-ESIG 3-3-1.
5. WHEN MORE THAN ONE SERVICE IS PROVIDED, A SERVICE PEDESTAL IS REQUIRED. IT IS CAPABLE OF ACCOMMODATING FIVE SERVICES. SEE UG PAGE 1-9-71 (SIM-ESIG 3-4-5).
6. CONTRACTOR TO COIL CONDUCTOR AT BASE OF POLE.
7. DTE TO FURNISH AND INSTALL CABLE POLE AND TERMINATE CABLE.
8. DETAIL TO BE USED AT TRUCK ACCESSIBLE LOCATIONS ONLY.

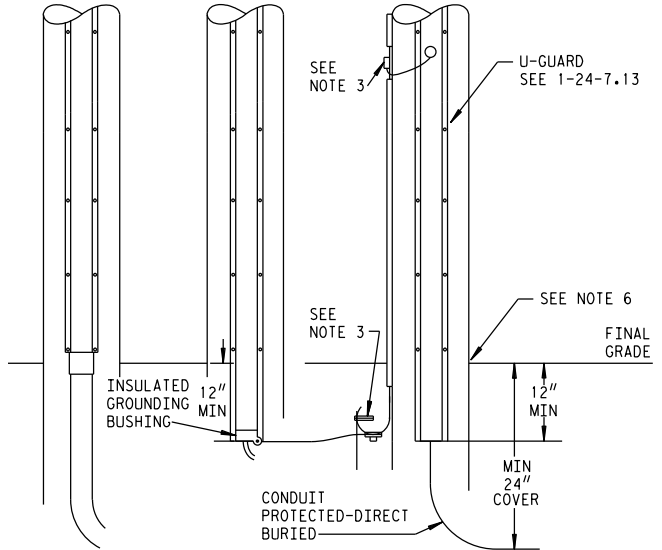

DETAIL 984A  
UNFUSED

DETAIL 986A  
FUSED

DTE ELECTRIC COMPANY ASSUMES NO RESPONSIBILITY FOR INJURY OR DAMAGE ARISING FROM THE USE OF THIS SPECIFICATION DIAGRAM.



SECONDARY UNDERGROUND SERVICE INSTALLATION ON STEEL POLES OR NON-TRUCK ACCESSIBLE WOOD POLES CABLE SIZE UP TO 350 KCMIL AL

USE OF THIS DETAIL DEPENDS ON CONDITIONS IN NOTES  
 120/240 120/208Y 277/480Y  
 ONE OR TWO UNDERGROUND SERVICES PER POLE - SEE NOTE 5

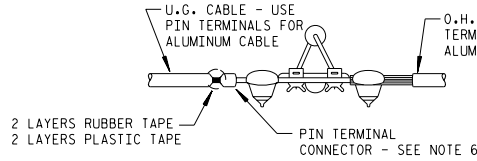
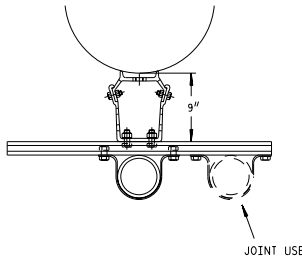

FUSE CARRIERS

O.H. COPPER TRAINER OR PIN TERMINAL SIZE	FUSE CARRIER IM No.
No. 2 AND No. 4/0	100032869
350	100015392

U.G. REFER TO PAGE 1-24-703 THRU 1-24-733 FOR TERMINAL LUGS  
 O.H. REFER TO PAGE 1-24-8.6 FOR TERMINAL CONNECTOR

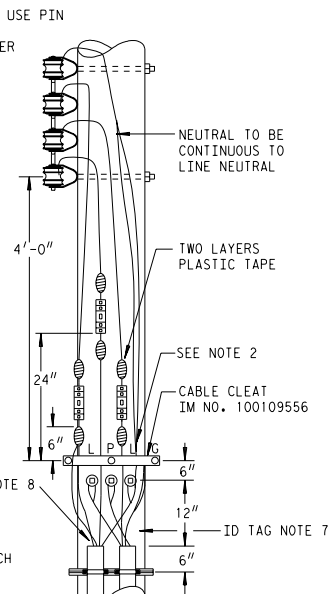

NOTES:

- SERVICE PLANNER DETERMINES DTE FUSE REQUIREMENTS ON POLE. PER SIM PAGE 12-4-11 & 12-4-12.
- IMPORTANT: FOR CONDUCTOR IDENTIFICATION AND POLE QUADRANT ASSIGNMENT, SEE PAGE 3-4-11 SIM-ESIG OR 1-9-93 LINES CONSTRUCTION MANUAL.
- STEEL CONDUIT SHALL BE GROUNDED BY INSTALLER IN ACCORDANCE WITH ARTICLES 230 & 250 OF THE NATIONAL ELECTRIC CODE. THEY MAY BE GROUNDED TO DTE GROUNDING CONDUCTOR IF AVAILABLE ON THE POLE. IF THE CONDUIT IS STEEL AND CONTINUOUS TO THE BUILDING, DO NOT GROUND AT THE POLE. PLEASE REFER TO PAGE 1-24-621 IN THE UG SPEC. BOOK FOR THE ITEM MASTER NUMBERS FOR THE STEEL CONDUIT. STEEL CONDUIT USED IN VEHICLE ACCESS AREAS, FOR 100% CONDUIT PLEASE REFER TO 1-9-227 FOR THE SWEEP REQUIREMENTS.
- MINIMUM NO. 2 COPPER SIZE POWER OR NEUTRAL CONDUCTOR. SERVICE PLANNER MUST APPROVE SIZE AND INSULATION SEE 3-3-1 SIM-ESIG. SEE FUSE CARRIER TABLE ABOVE.
- WHEN MORE THAN ONE SERVICES IS PROVIDED, A SERVICE PEDESTAL IS RECOMMENDED. WHERE MORE THAN TWO SERVICES ARE PROVIDED, A SERVICE PEDESTAL IS REQUIRED. IT IS CAPABLE OF ACCOMMODATING FIVE SERVICES SEE PAGE 3-4-5 SIM-ESIG OR 1-9-71 LINES CONSTRUCTION STANDARDS MANUAL.
- PIN TERMINALS TO BE USED WHEN ONE CONDUCTOR PER PHASE PER CUSTOMER IS PRESENT. USE 2 HOLE TERMINALS FOR TWO CONDUCTORS PER PHASE PER CUSTOMER AND BOLT BACK TO BACK WHEN CONNECTING TO FUSE CARRIER.
- INSTALL O.H./U.G. IDENTIFICATION TAG ABOVE CONDUIT.  
 O.H. FED - IM NO. 100044127  
 U.G. FED - IM NO. 100063172
- USE DUCT SEAL TO SEAL THE CABLES. IF CUSTOMER RUNS 100% CONDUIT, INSTALL SWEEP. SWEEP SHALL PROTRUDE 4 TO 12 INCHES ABOVE FINAL GRADE.
- TO INSTALL BRACKET USE ONE 5/8" BOLT FOR TOP MOUNTING HOLE AND 1/2" LAG FOR THE BOTTOM BOLT. USE ONE 5/8" BOLT FOR TOP MOUNTING HOLE AND BANDING FOR THE BOTTOM BOLT TO MOUNT ON STEEL POLES. MINIMUM CLASS 4 POLE SIZE REQUIRED FOR CABLE STANDOFF BRACKETS. ACTUAL POLE SIZE SHOULD BE DETERMINED BY PLANNER.
- FOR USE ON WOOD POLES, DETAIL SHALL ONLY BE BUILT IN NON-TRUCK ACCESSIBLE LOCATIONS.
- CABLE STANDOFF SHALL BE USED FOR ALL SECONDARY CABLE ON STEEL POLES.
- DETAIL TO BE USED ONLY FOR CABLE SIZES UP TO AND INCLUDING 350 KCMIL AL.

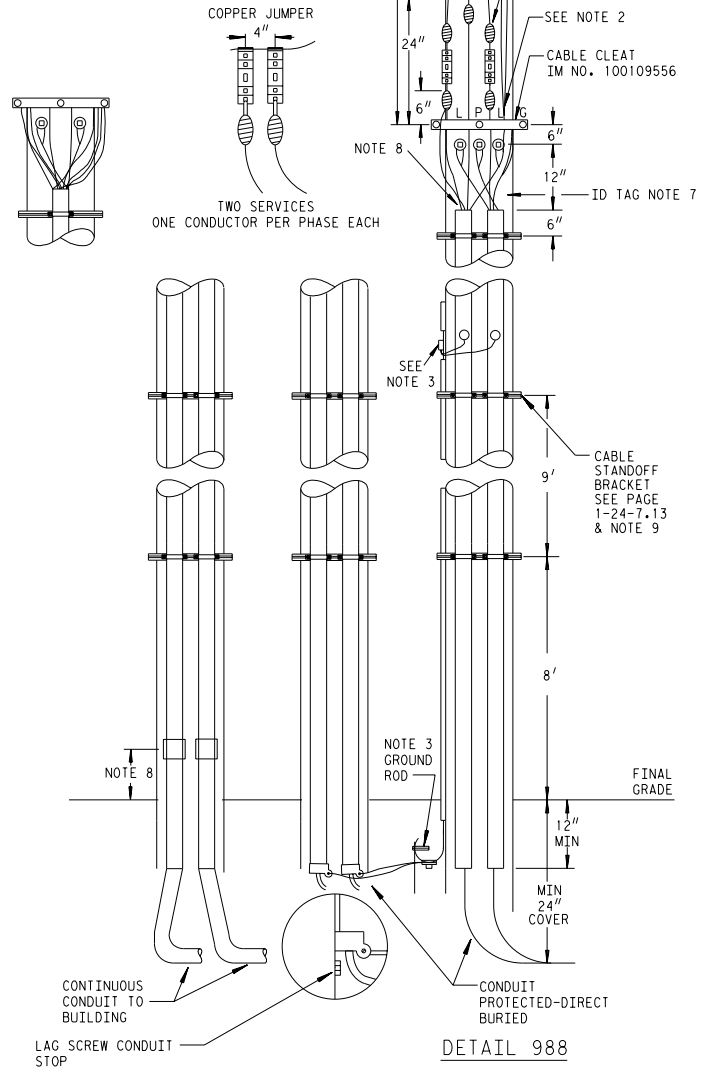

DTE ELECTRIC COMPANY ASSUMES NO RESPONSIBILITY FOR INJURY OR DAMAGE ARISING FROM THE USE OF THIS SPECIFICATION DIAGRAM.

SECONDARY UNDERGROUND SERVICE INSTALLATION ON TRUCK ACCESSIBLE WOOD POLE ONLY  
CABLE SIZE 4/0 TO 500 kcmil Cu OR 350 TO 500 kcmil Al

USE OF THIS DETAIL DEPENDS ON CONDITIONS IN NOTES  
120/240 120/208Y 277/480Y  
ONE OR TWO UNDERGROUND SERVICES PER POLE - SEE NOTE 5

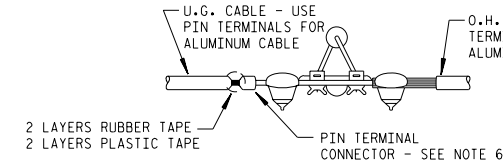

FUSE CARRIERS

O.H. COPPER TRAINER OR PIN TERMINAL SIZE	FUSE CARRIER IM NO.
No. 2 AND No. 4/0	100032869
350 THRU 500+	100015392

U.G. REFER TO PAGE 1-24-703 THRU 1-24-733 FOR TERMINAL LUGS  
O.H. REFER TO PAGE 1-24-8.6 FOR TERMINAL CONNECTOR  
\* 500 TRAINER OR 636 PIN TERMINAL

COPPER JUMPER

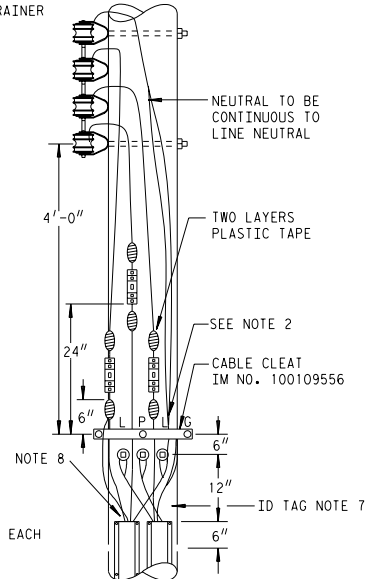
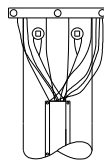

NOTES:

- SERVICE PLANNER DETERMINES DTE FUSE REQUIREMENTS ON POLE. PER SIM PAGE 12-4-11 & 12-4-12.
- IMPORTANT: FOR CONDUCTOR IDENTIFICATION AND POLE QUADRANT ASSIGNMENT, SEE PAGE 3-4-11 SIM-ESIG OR 1-9-93 LINES CONSTRUCTION MANUAL.
- STEEL U-GUARD SHALL BE GROUNDED BY INSTALLER IN ACCORDANCE WITH ARTICLES 230 & 250 OF THE NATIONAL ELECTRIC CODE. THEY MAY BE GROUNDED TO DTE GROUNDING CONDUCTOR IF AVAILABLE ON THE POLE. IF THE UG CONDUIT IS STEEL AND CONTINUOUS TO THE BUILDING, DO NOT GROUND AT THE POLE. PLEASE REFER TO PAGE 1-24-621 IN THE UG SPEC. BOOK FOR THE ITEM MASTER NUMBERS FOR THE STEEL U-GUARD. STEEL U-GUARD TO BE USED IN VEHICLE ACCESS AREAS OTHERWISE PLASTIC U-GUARD TO BE USED.
- MINIMUM NO. 4/0 COPPER SIZE POWER OR NEUTRAL CONDUCTOR. SERVICE PLANNER MUST APPROVE SIZE AND INSULATION SEE 3-3-1 SIM-ESIG.
- WHEN MORE THAN ONE SERVICES IS PROVIDED, A SERVICE PEDESTAL IS RECOMMENDED. WHERE MORE THAN TWO SERVICES ARE PROVIDED, A SERVICE PEDESTAL IS REQUIRED. IT IS CAPABLE OF ACCOMMODATING FIVE SERVICES SEE PAGE 3-4-5 SIM-ESIG OR 1-9-71 LINES CONSTRUCTION STANDARDS MANUAL.
- PIN TERMINALS TO BE USED WHEN ONE CONDUCTOR PER PHASE PER CUSTOMER IS PRESENT. USE 2 HOLE TERMINALS FOR TWO CONDUCTORS PER PHASE PER CUSTOMER AND BOLT BACK TO BACK WHEN CONNECTING TO FUSE CARRIER.
- INSTALL O.H./U.G. IDENTIFICATION TAG ABOVE U-GUARD.  
O.H. FED IM NO. 100044127  
U.G. FED IM NO. 100063172
- DETAIL TO BE USED AT TRUCK ACCESSIBLE LOCATIONS FOR WOOD POLES ONLY.
- DETAIL NOT TO BE USED AT STEEL POLE LOCATIONS. REFER TO DETAIL 988.

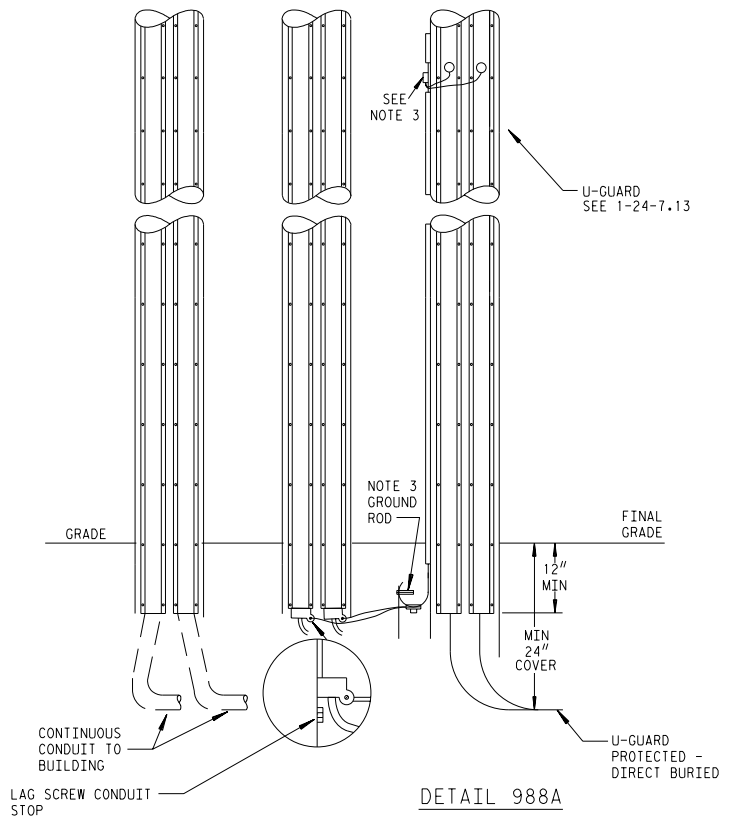

DTE ELECTRIC COMPANY ASSUMES NO RESPONSIBILITY FOR INJURY OR DAMAGE ARISING FROM THE USE OF THIS SPECIFICATION DIAGRAM.

MULTIPLE SECONDARY UNDERGROUND SERVICE INSTALLATION THREE CONDUCTOR PER PHASE  
STEEL POLE OR NON-TRUCK ACCESSIBLE WOOD POLE CABLE SIZE 1/0 TO 350 KCMIL

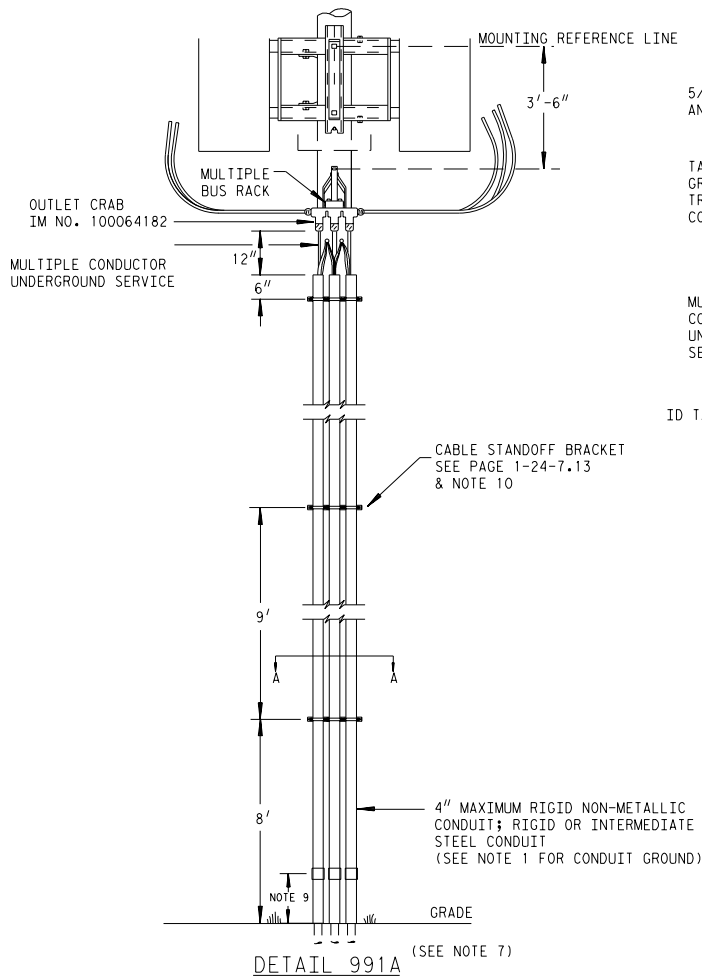

DETAIL 991A (SEE NOTE 7)

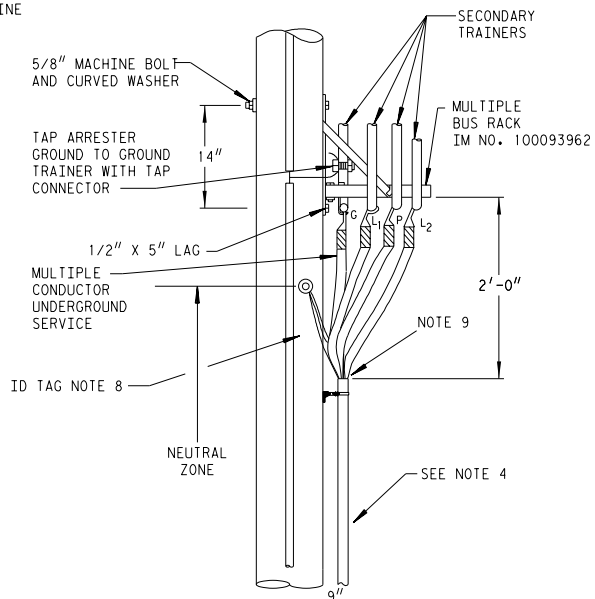

DETAIL 991B  
(SEE NOTE 7)

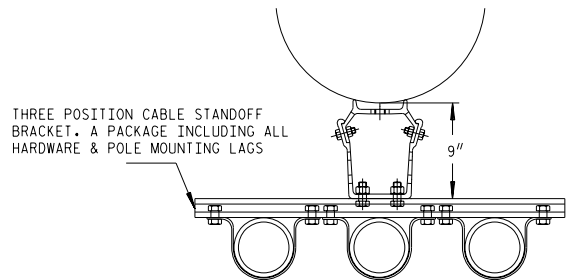

SECTION A-A  
THREE POSITION CABLE STANDOFF BRACKET  
(SEE NOTE 7)

NOTES:

1. STEEL CONDUIT SHALL BE GROUNDED BY INSTALLER IN ACCORDANCE WITH ARTICLES 230 & 250 OF THE NATIONAL ELECTRIC CODE. THEY MAY BE GROUNDED TO DTE GROUNDING. PLEASE REFER TO PAGE 1-24-621 IN THE UNDERGROUND SPEC. BOOK FOR THE ITEM MASTER NUMBERS FOR THE STEEL CONDUIT. CONDUIT IF AVAILABLE ON THE POLE. IF THE CONDUIT IS STEEL AND CONTINUOUS TO THE BUILDING, DO NOT GROUND AT THE POLE. STEEL CONDUIT USED IN AREA WHERE VEHICLES HAVE ACCESS OTHERWISE SCHEDULE 40 WILL BE USED. FOR 100% CONDUIT PLEASE REFER TO 1-9-227 FOR THE SWEEP REQUIREMENTS.
2. IN ALLEYS, CONDUIT MUST BE ON PROPERTY SIDE OF POLE ON THREE CONDUIT JOBS.
3. SEE LINE CONSTRUCTION STANDARDS 1-9-268 OR SIM 3-4-13 FOR CABLE SUPPORT SIZE AND IM NUMBERS.
4. SERVICE CONDUCTORS MUST BE CLEARLY IDENTIFIED PER LINES CONSTRUCTION STANDARDS 1-9-93 OR SIM-ESIG 3-4-11.
5. ALL POSITIONS ON BUS ARE FOR 2 HOLE TERMINALS LISTED ON O.H. PAGE 1-24-8.6 AND U.G. PAGES 1-24-703 THRU 1-24-731.
6. COVER ALL BUS POSITIONS WITH 1 LAYER FRICTION TAPE AND ONE CONNECTOR PAD ED. NO. 760-0424.
7. FOREIGN CONTACT SHOULD NOT BE MADE ON POLE UNLESS PERMITTED BY SERVICE PLANNER.
8. INSTALL OH/UG IDENTIFICATION TAG ABOVE CABLE STANDOFF BRACKET. OH-FED IM NO. 100044127, UG-FED IM NO. 100063172
- ➡ 9. USE DUCT SEAL TO SEAL THE CABLES. IF CUSTOMER RUNS 100% CONDUIT, INSTALL SWEEP. SWEEP SHALL PROTRUDE 4 TO 12 INCHES ABOVE FINAL GRADE.
10. ON WOOD POLES, TO INSTALL BRACKET USE ONE 5/8" BOLT FOR TOP MOUNTING HOLE AND 1/2" LAG FOR THE BOTTOM HOLE. TO INSTALL ON STEEL POLES, USE ONE 5/8" BOLT FOR TOP HOLE AND BAND BOTTOM HOLE. MINIMUM CLASS 4 POLE SIZE REQUIRED FOR CABLE STANDOFF BRACKETS. ACTUAL POLE SIZE SHOULD BE DETERMINED BY PLANNER.
11. FOR USE ON WOOD POLES, DETAIL SHALL ONLY BE BUILT IN NON-TRUCK ACCESSIBLE LOCATIONS.
12. CABLE STANDOFF SHALL BE USED FOR ALL SECONDARY CABLE ON STEEL POLES.
- ➡ 13. DETAIL TO BE USED ONLY FOR CABLE SIZES UP TO AND INCLUDING 350 KCMIL AL.

DTE ELECTRIC COMPANY ASSUMES NO RESPONSIBILITY FOR INJURY OR DAMAGE ARISING FROM THE USE OF THIS SPECIFICATION DIAGRAM.

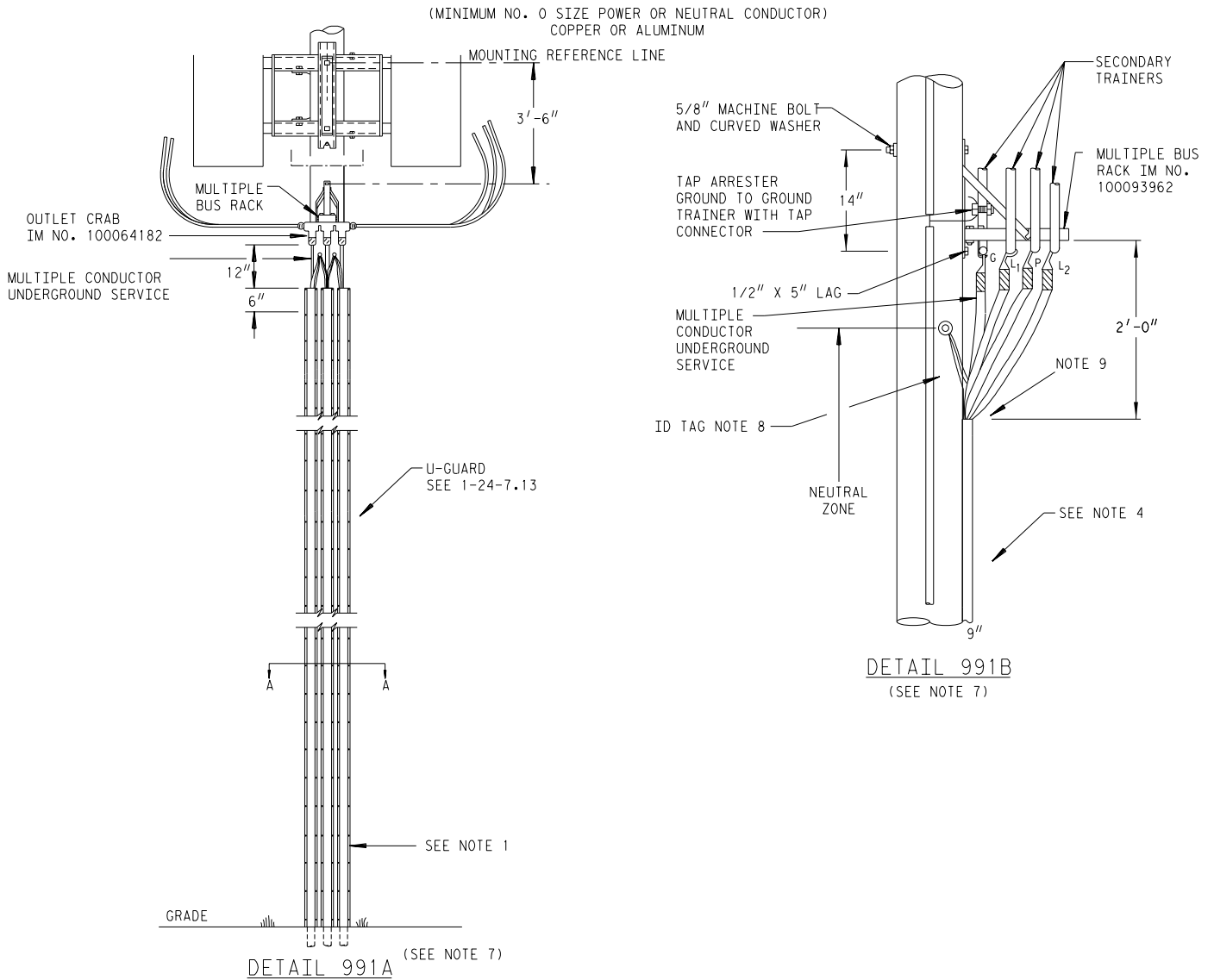

**NOTES:**

1. STEEL U-GUARD SHALL BE GROUNDED BY INSTALLER IN ACCORDANCE WITH ARTICLES 230 & 250 OF THE NATIONAL ELECTRIC CODE. THEY MAY BE GROUNDED TO DTE GROUNDING. PLEASE REFER TO PAGE 1-24-621 IN THE UNDERGROUND SPEC. BOOK FOR THE ITEM MASTER NUMBERS FOR THE STEEL U-GUARD. IF THE UG CONDUIT IS STEEL AND CONTINUOUS TO THE BUILDING, DO NOT GROUND AT THE POLE. STEEL U-GUARD USED IN AREA WHERE VEHICLES HAVE ACCESS OTHERWISE PLASTIC U-GUARD TO BE USED.
2. SEE LINE CONSTRUCTION STANDARDS 1-9-268 OR SIM 3-4-13 FOR CABLE SUPPORT SIZE AND IM. NUMBERS.
3. SERVICE CONDUCTORS MUST BE CLEARLY IDENTIFIED PER LINES CONSTRUCTION STANDARDS 1-9-93 OR SIM-ESIG 3-4-11.
4. ALL POSITIONS ON BUS ARE FOR 2 HOLE TERMINALS LISTED ON O.H. PAGE 1-24-8.6 AND U.G. PAGES 1-24-703 THRU 1-24-731.
5. COVER ALL BUS POSITIONS WITH 1 LAYER FRICTION TAPE AND ONE CONNECTOR PAD IM NO. 100114181.
6. FOREIGN CONTACT SHOULD NOT BE MADE ON POLE UNLESS PERMITTED BY SERVICE PLANNER.
7. INSTALL OH/UG IDENTIFICATION TAG ABOVE U-GUARD.  
OH-FED IM NO. 100044127  
UG-FED IM NO. 100063172
8. DETAIL TO BE USED AT TRUCK ACCESSIBLE LOCATIONS FOR WOOD POLES ONLY.
9. DETAIL NOT TO BE USED AT STEEL POLE LOCATIONS. REFER TO DETAIL 991.

DTE ELECTRIC COMPANY ASSUMES NO RESPONSIBILITY FOR INJURY OR DAMAGE ARISING FROM THE USE OF THIS SPECIFICATION DIAGRAM.

1-9-93

SERVICE CONDUCTOR IDENTIFICATION  
POSITIONING CONDUCTORS ON CABLE POLE

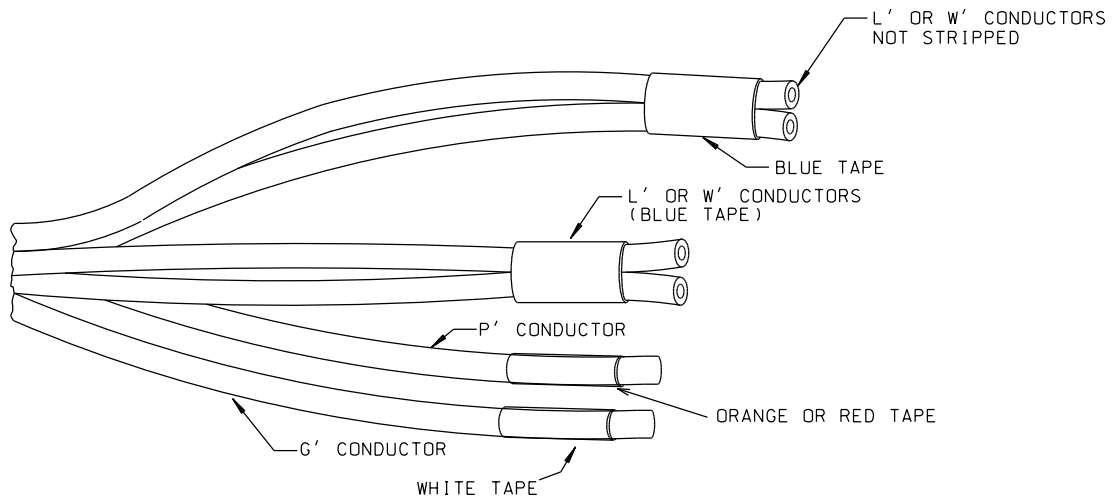

SERVICE CONDUCTOR IDENTIFICATION

THE POLE QUADRANT LOCATIONS SHOWN ARE TO ASSURE PROPER CLIMBING AND WORKING SPACE AND WILL BE ASSIGNED BY THE SERVICE PLANNER WHO WILL COORDINATE WITH THE TELEPHONE COMPANY ON JOINT USE POLES.

FIRST CHOICE

SECOND CHOICE

TRANSFORMER POLE

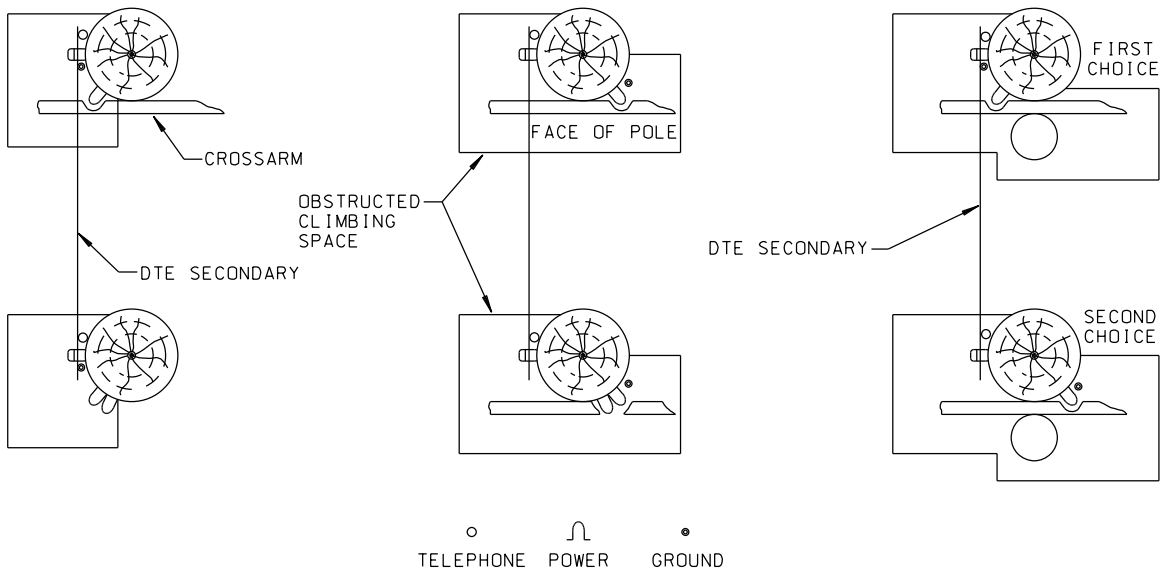

PRIMARY AND SECONDARY CABLE LOCATION AT CABLE POLE

NOTE:

ON ALL PRIMARY DEADEND POLES, CABLES FOR ALL NEW COMMERCIAL FEEDER, PRIMARY CUSTOMER AND URD CABLES WILL BE INSTALLED ON THE SIDE OPPOSITE THE GUY.

DTE ELECTRIC COMPANY ASSUMES NO RESPONSIBILITY FOR INJURY OR DAMAGE ARISING FROM THE USE OF THIS SPECIFICATION DIAGRAM.

TEMPORARY SERVICE PEDESTAL INSTALLATION  
WIRE SIZE #8 THRU #2 AWG

THE SPECIFICATION CONTAINED HEREIN  
SHALL APPLY ONLY TO TEMPORARY SERVICES.

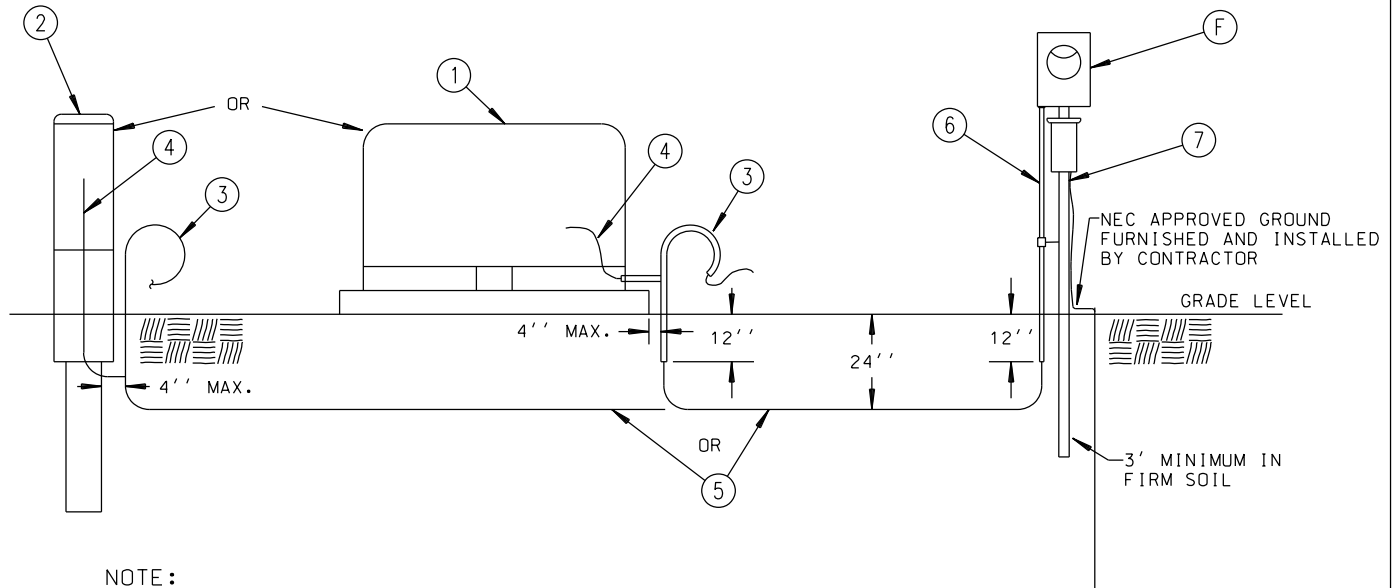

NOTE:

SERVICE CONNECTIONS WILL BE MADE TO TRANSFORMER ONLY WHEN NO PEDESTAL EXISTS

LEGEND:

1. DTE ELECTRIC TRANSFORMER.
2. DTE ELECTRIC SECONDARY PEDESTAL.
3. CONTRACTOR TO FURNISH:
  - A. FOR TRANSFORMER ONLY OPTION - LIQUIDTIGHT FLEXIBLE METAL CONDUIT INSTALLED ON CABLE FROM 12'' BELOW GRADE TO THE 2'' OPENING IN THE BASE OF THE SECONDARY COMPARTMENT.
  - B. FOR TRANSFORMER ONLY OPTION - A LIQUIDTIGHT FLEXIBLE METAL CONDUIT FITTING WITH REDUCER WASHERS TO FIT A 2'' OPENING.
  - C. FOR TRANSFORMER OR PEDESTAL OPTION - 4 FEET OF CABLE BEYOND THE END OF THE LIQUIDTIGHT FLEXIBLE METAL CONDUIT.
4. DTE ELECTRIC TO INSTALL AND TERMINATE CUSTOMER'S UG CABLE IN TRANSFORMER OR PEDESTAL.
5. LISTED UG CABLE FURNISHED AND INSTALLED BY CONTRACTOR.
6. CONDUIT FURNISHED AND INSTALLED BY CONTRACTOR.
7. TEMPORARY SERVICE PEDESTAL FURNISHED AND INSTALLED BY CONTRACTOR. SEE PAGE 1-9-242/SIM-ESIG PAGE 3-5-12 FOR CONSTRUCTION DETAILS. ALTERNATE PRECONSTRUCTION METER MOUNT WHEN APPROVED BY SERVICE PLANNER. SEE PAGE 1-9-225/SIM-ESIG PAGES 3-12-1 THRU 3-12-4.

NOTES:

- A. REFER TO SIM-ESIG PAGE 3-5-15 FOR INFORMATION RELATING TO UG SERVICE.
- B. LINE CONDUCTORS MAY ENTER METER ENCLOSURE THROUGH BOTTOM OF CABINET.
- C. LOAD CONDUCTORS MAY LEAVE METER ENCLOSURE THROUGH BOTTOM OR BACK OF CABINET.
- D. THE ELECTRICAL CONTRACTOR WILL BE RESPONSIBLE FOR LEAVING SUFFICIENT CABLE TO ALLOW 4 FEET INSIDE THE TRANSFORMER OR PEDESTAL.
- E. TEMPORARY SERVICE PEDESTAL SHOULD NOT BE INSTALLED IN UTILITY EASEMENT.
- ➔ F. ANY BOND BETWEEN THE METER ENCLOSURE AND JOINT USERS THAT INTERFERES WITH REMOVING THE COVER ON THE METER BOX IS A VIOLATION OF NEC 250.94 (3). THE JOINT USER WHO CREATED THE VIOLATION MUST CORRECT THE SITUATION.

DTE ELECTRIC COMPANY ASSUMES NO RESPONSIBILITY FOR INJURY  
OR DAMAGE ARISING FROM THE USE OF THIS SPECIFICATION DIAGRAM.

TEMPORARY SERVICE PEDESTAL  
WIRE SIZE #8 THRU #2

THE SPECIFICATION CONTAINED HEREIN SHALL APPLY ONLY TO TEMPORARY SERVICES.

FOR 3Ø SERVICES AND 1Ø SERVICES LARGER THAN #2, SEE PAGE 3-4-6

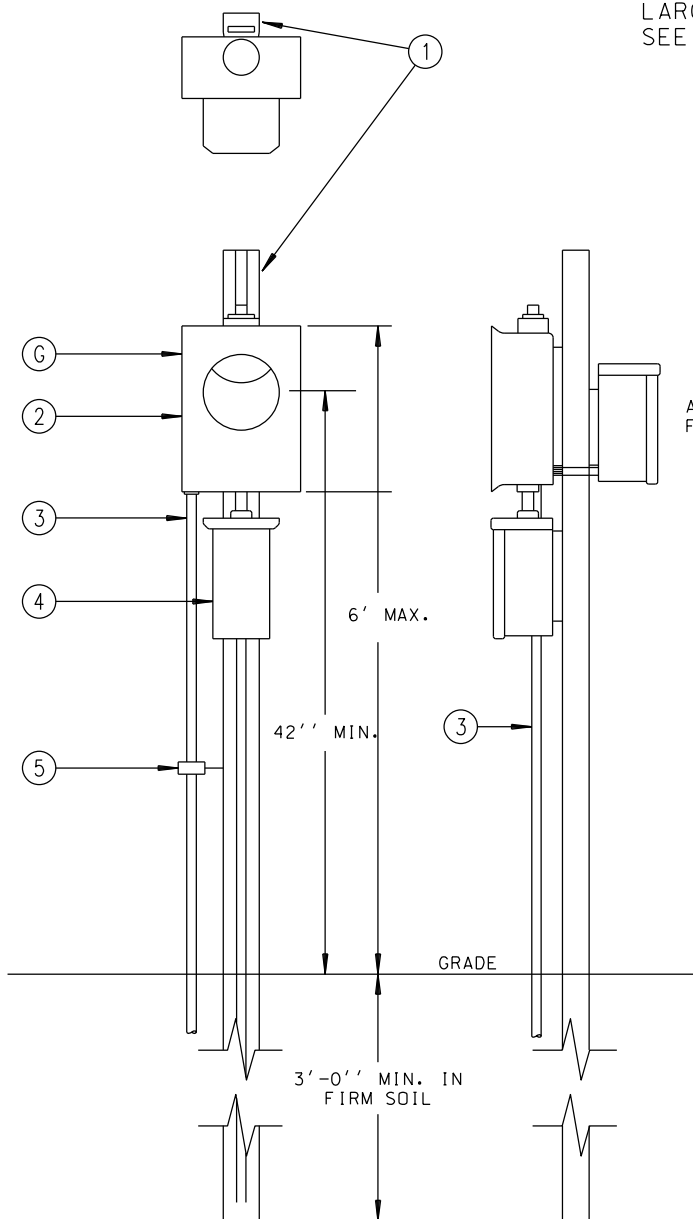

LEGEND :

1. UNISTRUT P-1000 (NUMBER SHOWN FOR CONVENIENCE) OR EQUIVALENT. CONSTRUCTION FURNISHED AND INSTALLED BY CONTRACTOR.
2. 1 PHASE CL 200 METER ENCLOSURE FURNISHED AND INSTALLED BY CONTRACTOR.
3. CONDUIT WITH BUSHINGS FURNISHED AND INSTALLED BY CONTRACTOR.
4. POWER OUTLET CABINET FURNISHED AND INSTALLED BY CONTRACTOR.
5. CONDUIT SUPPORT CLAMP.

NOTES :

- A. POST OR STAKE MAY BE DRIVEN OR AUGERED.
- B. ANGLE BRACING MAY BE USED IF DESIRED.
- C. DO NOT LOCATE PEDESTAL IN EASEMENT.
- D. LINE CONDUCTORS MAY BE INSTALLED THROUGH BOTTOM OF METER ENCLOSURE.
- E. LOAD CONDUCTORS MAY BE INSTALLED THROUGH BOTTOM OR OUT BACK OF METER ENCLOSURE.
- F. REFER TO SIM-ESIG PAGE 3-5-11 FOR INSTALLATION.

➔ G. ANY BOND BETWEEN THE METER ENCLOSURE AND JOINT USERS THAT INTERFERES WITH REMOVING THE COVER ON THE METER BOX IS A VIOLATION OF NEC 250.94 (3). THE JOINT USER WHO CREATED THE VIOLATION MUST CORRECT THE SITUATION.

DTE ELECTRIC COMPANY ASSUMES NO RESPONSIBILITY FOR INJURY OR DAMAGE ARISING FROM THE USE OF THIS SPECIFICATION DIAGRAM.

**INSTALLATION PROCEDURE FOR SECONDARY METERED SERVICE**

The following instructions are for the customer's contractor in those situations where DTE Electric policy or *Michigan Public Service Commission* (MPSC) rules require customer installation of underground secondary service conductors.

The type and location of distribution equipment is a DTE Electric Planner decision based on the size of the customer's load and the distribution facilities available.

**1. Work Around Secondary Power Sources.**

- (a) **Equipment Access.** Only DTE Electric personnel or authorized DTE contractors may open transformers and service pedestals or work above the ten-foot level on DTE Electric poles.
- (b) **Digging in Easements.** In those cases where the customer's contractor is required to install the secondary service conductors to the distribution equipment, the contractor will hand dig in the easement to the customer's property line. The contractor will always notify *Miss Dig* to stake the location of any underground facilities before beginning work. The contractor will not excavate more than 30 inches below grade or do any machine excavating in an easement or within 3 feet of a power source. If the route of the cable must cross another party's property or onto public property, arrangements must be made with the DTE Electric Planner for completion of that portion by DTE Electric crews.
- (c) **Adequate Cable Length.** The electrical contractor will be responsible for leaving sufficient cable at the source for proper termination by DTE Electric personnel. Specifically, 6 feet of extra cable is required inside a transformer or pedestal and 5 feet beyond the secondary rack on a secondary cable pole. Since the contractor will generally not install the cable into the equipment or all the way up the pole, some judgment will be necessary. In some cases, the DTE Electric Planner may find it necessary to alter these dimensions. In any case, where it is not clear, the contractor should consult with the DTE Electric Planner.

**2. Contractor Instructions.**

At the source, the contractor will proceed according to one of the following situations:

- (a) **Padmount Transformer--Energized.**
  - (1) **Direct buried.** Trench to the transformer, hand digging the last three feet, but make no attempt to tunnel underneath. Leave sufficient cable to properly terminate in the transformer.
  - (2) **Existing conduit.** Arrange for DTE Electric crews to assist in pulling cable into the transformer.
  - (3) **Conduit to be installed.** Trench and install conduit to within three feet of the transformer. DTE Electric crews will assist in installing the last three feet of conduit, the sweep, and in pulling the cable.



**(b) Padmount Transformer--Not Energized.**

The electrical contractor will bring sufficient cable underneath the transformer pad and into the secondary compartment for DTE Electric personnel to properly terminate. The DTE Electric Planner will arrange to unlock the transformer and will be responsible for locking it when the contractor's work is complete.

**(c) Padmount Transformer--Not on Job Site.**

The electrical contractor will bring sufficient cable up into the secondary window area of the padmount foundation for DTE Electric personnel to properly terminate.

**(d) Pedestals.**

The electrical contractor will trench to the pedestal, hand digging the last three feet, and leave sufficient cable for DTE Electric personnel to properly terminate.

**(e) One or Two Services from a Pole.**

The electrical contractor will bring the cable to the pole quadrant designated by the DTE Electric Planner and provide conduit to ten feet above grade. The contractor will leave sufficient cable to reach 5 feet beyond the secondary rack or as directed by the DTE Electric Planner. DTE Electric personnel will train and cover the cable above the ten-foot level and connect to the overhead secondary source. (See page 3-4-7.)

Before instructing an electrical contractor to install service for training up a pole, consideration should be given to possible future services. If it appears that more than two single conductor per phase underground services may be brought to this pole, the DTE Electric Planner should arrange for installation of a pedestal as described below.

**(f) More than Two Services from a Pole.**

DTE Electric will furnish and install a secondary connection pedestal in the easement for terminating up to five services. Edison personnel will furnish and install the supply cable to the pedestal and connect to the overhead secondary source as shown on page 3-4-5. The electrical contractor will proceed as described in (d) above. The DTE Electric Planner will specify the location of the pedestal as follows:

- (1) The pedestal will be located in the easement on the property of one of the customers requesting service, preferably at the corner of the lot.
- (2) Every effort should be made to avoid installing the pedestal on the same property as the overhead distribution pole.

(g) **Network Underground Cable.**

In certain central business district areas, power will be provided from a wye network. (See pages 2-1-5 to 2-1-8 for network maps.) The only service available will be 120/208 V three-wire single-phase or four-wire three-phase. If the lighting demand for the building exceeds 15 kilowatts, a four-wire three-phase service must be installed and the lighting load balanced on all three phases. This will also be true for service to a tenant who is renting or leasing a portion of the building. DTE will extend conduit to the customer's property line from the source. The source may be a manhole or a cable pole. DTE Electric will install the service cable from the source to the service entrance point.

(h) **Rights-of-Way.**

In the above situations, Public Utility Easements or Rights-of-Way must be granted before distribution work can begin. Cable routing in easements must follow the Service Routing Guide on pages 3-1-8 to 3-1-10.

**3. Service Laterals from Underground Distribution.**

(a) **Residential.**

- (1) **Customer requests.** The customer, electrical contractor, or developer will arrange for service laterals directly with the Regional Center. (See pages 1-2-1 to 1-2-9 for Regional Center locations.)
- (2) **Standard service.** DTE will trench and install a standard 3/0 AWG aluminum service from the source, routed as shown in the Service Routing Guide on pages 3-1-8 to 3-1-10.
- (3) **Large demands.** Larger than normal demands or long runs may require the use of a 350 kcmil aluminum service at additional cost. Consult the DTE Electric Planner. All service conductors furnished by DTE Electric will be sized in accordance with DTE diversity and ampacity tables.

(b) **Commercial.**

- (1) **Conduit required.** Where the area is not suitable for direct burial, the customer's contractor will trench and install ducts for the service laterals. *Most commercial services must be in conduit.* Consult the DTE Electric Planner.
- (2) **Self-contained meters or tap boxes.** DTE will furnish, install, own, and maintain appropriately sized laterals to self-contained meter enclosures or secondary connection cabinets. (See *Schedule of Rates* Rule B-3.5.)
- (3) **CT cabinets and switchboards.** The customer will own and maintain, and his electrician will furnish and install services to current transformer cabinets and switchboards. Conductors will be sized in accordance with the NEC.

**4. Underground Service from Overhead Distribution.**

- (a) **Residential.** Under MPSC rules, all new, relocated or upgraded residential service connections will be installed as underground residential service lateral at the customer's expense. Therefore, it is necessary for the Company to adapt the overhead distribution system to supply an underground service.
- (b) **Commercial.** Underground secondary service laterals may be served directly from overhead distribution if the existing overhead facilities have adequate capacity to serve the additional load. Consult the DTE Electric Planner.

CONCRETE TRANSFORMER PAD  
(SECONDARY METERED)

1-56-101A  
1-43-32.1A

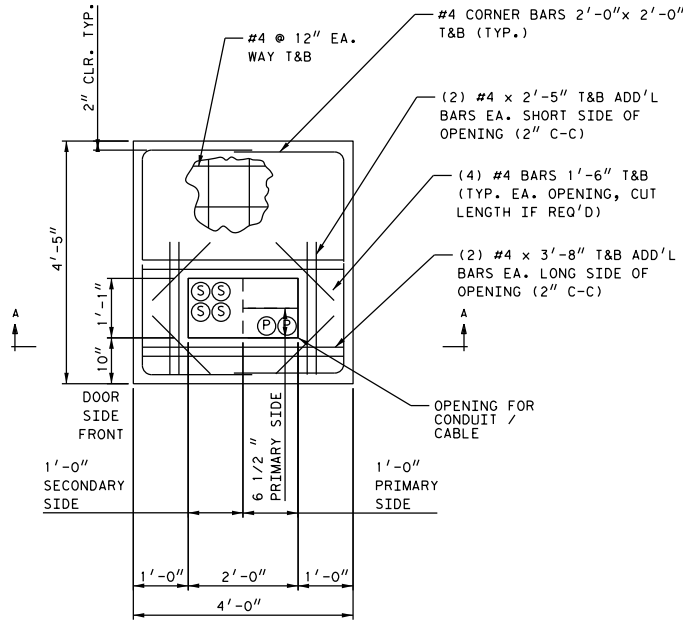

FOUNDATION PLAN VIEW

CONCRETE PAD FOR ALL SINGLE PHASE TRANSFORMERS EXCEPT 4.8kV SWITCHING  
SEE SECTION 'A-A' FOR ADD'L REINFORCING.

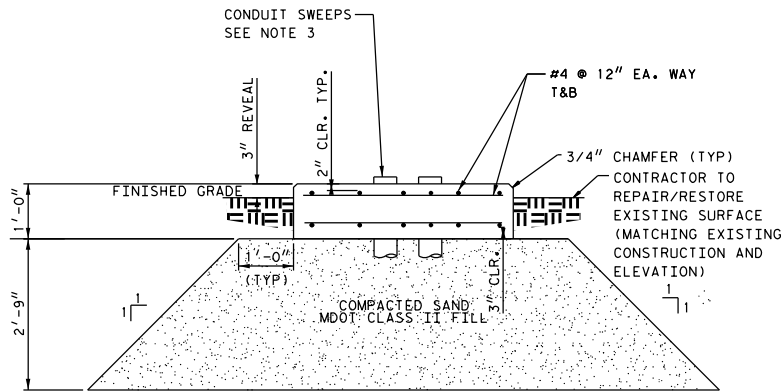

SECTION 'A-A'

NOTE: NOT TO SCALE.

NOTES:

1. THIS SPECIFICATION IS FOR PADS CAST IN PLACE OR PRECAST.
2. REFER TO 3-6-14 TO 3-6-15 FOR GENERAL NOTES.
3. FIELD TO LOCATE AND POSITION ALL CONDUIT SLEEVES FOR CABINETS PRIOR TO PLACING CONCRETE. THE NUMBER OF DUCTS IS TO BE APPROVED BY THE SERVICE PLANNER/REGIONAL ENGINEER.
4. MAT FOUNDATION DESIGNED ASSUMING 1,000 PSF ALLOWABLE SOIL BEARING CAPACITY.
5. FOR GROUND ROD INSTALLATION DETAIL SEE 3-6-9.
6. FOR MINIMUM CLEARANCE TO OBSTRUCTION SEE 3-7-11.
7. FOR ANCHOR BOLT INSTALLATION DETAIL, SEE 3-6-10.
8. 1/2" TOP TO BOTTOM TAPER ALLOWED IN CONDUIT PLACEMENT OPENING.
9. PRIMARY CONDUIT MUST BE POSITIONED AT THE FRONT OF THE WINDOW.
10. TRANSFORMER AND PAD SELECTION ON SECONDARY METERED INSTALLATIONS ARE DETERMINED BY THE DTE PLANNER.
11. A FIBERGLASS BOX PAD AS SHOWN ON 3-6-13 MAY BE SUBSTITUTED FOR THIS DETAIL. BOX PADS ARE AVAILABLE THROUGH DTE ELECTRIC INVESTMENT RECOVERY AT WARREN SERVICE CENTER - 313.897.1480.

DTE ELECTRIC COMPANY ASSUMES NO RESPONSIBILITY FOR INJURY OR DAMAGE ARISING FROM THE USE OF THIS SPECIFICATION DIAGRAM.

CONCRETE TRANSFORMER PAD  
(SECONDARY METERED)

1-56-101B  
1-43-32.1B

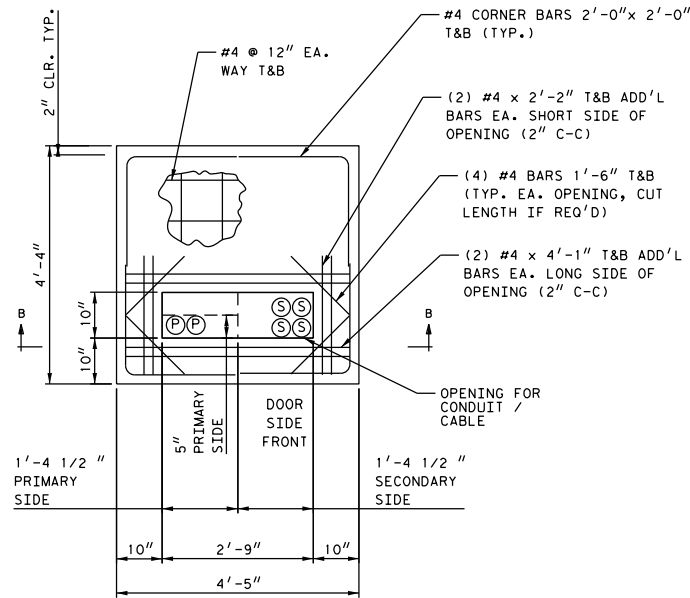

FOUNDATION PLAN VIEW

CONCRETE PAD FOR SINGLE PHASE 4800V SWITCHING TYPE TRANSFORMER,  
AND 75 AND 150 KVA THREE-PHASE NON-SWITCHING.

\* PREVIOUSLY USED FOR DUPLEX NON-SWITCHING UP THROUGH  
250 / 167 KVA, IDENTIFICATION ONLY.

SEE SECTION 'B-B' FOR ADD'L REINFORCING.

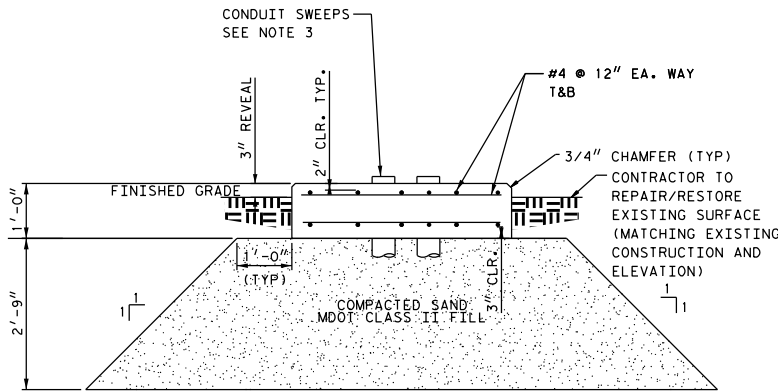

SECTION 'B-B'

NOTE: NOT TO SCALE.

NOTES:

1. THIS SPECIFICATION IS FOR PADS CAST IN PLACE OR PRECAST.
2. REFER TO 3-6-14 TO 3-6-15 FOR GENERAL NOTES.
3. FIELD TO LOCATE AND POSITION ALL CONDUIT SLEEVES FOR CABINETS PRIOR TO PLACING CONCRETE. THE NUMBER OF DUCTS IS TO BE APPROVED BY THE SERVICE PLANNER/REGIONAL ENGINEER.
4. MAT FOUNDATION DESIGNED ASSUMING 1,000 PSF ALLOWABLE SOIL BEARING CAPACITY.
5. FOR GROUND ROD INSTALLATION DETAIL SEE 3-6-9.
6. FOR MINIMUM CLEARANCE TO OBSTRUCTION SEE 3-7-11.
7. FOR ANCHOR BOLT INSTALLATION DETAIL, SEE 3-6-10.
8. 1/2" TOP TO BOTTOM TAPER ALLOWED IN CONDUIT PLACEMENT OPENING.
9. PRIMARY CONDUIT MUST BE POSITIONED AT THE FRONT OF THE WINDOW.
10. TRANSFORMER AND PAD SELECTION ON SECONDARY METERED INSTALLATIONS ARE DETERMINED BY THE DTE PLANNER.

DTE ELECTRIC COMPANY ASSUMES NO RESPONSIBILITY FOR INJURY OR DAMAGE ARISING FROM THE USE OF THIS SPECIFICATION DIAGRAM.

CONCRETE TRANSFORMER PAD  
(SECONDARY METERED)

1-56-102A  
1-43-32.2A

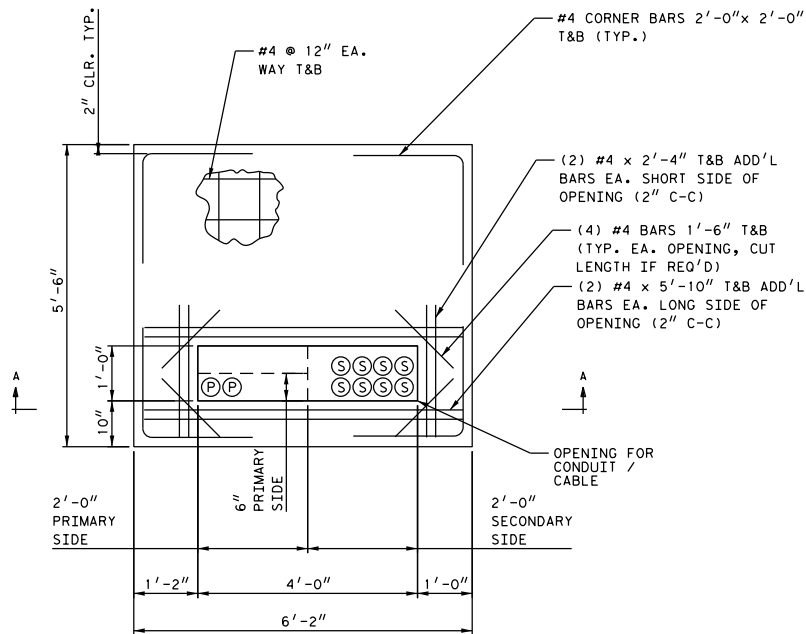

FOUNDATION PLAN VIEW

CONCRETE PAD FOR THREE-PHASE NON-SWITCHING TRANSFORMERS 300 AND 500 KVA, AND THREE-PHASE DEAD FRONT TRANSFORMERS 75 TO 750 KVA  
SEE SECTION 'A-A' FOR ADD'L REINFORCING.

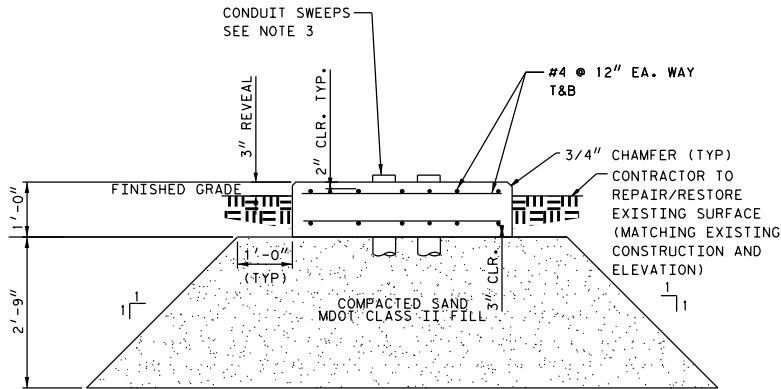

SECTION 'A-A'

NOTE: NOT TO SCALE.

NOTES:

1. THIS SPECIFICATION IS FOR PADS CAST IN PLACE OR PRECAST.
2. REFER TO 3-6-14 TO 3-6-15 FOR GENERAL NOTES.
3. FIELD TO LOCATE AND POSITION ALL CONDUIT SLEEVES FOR CABINETS PRIOR TO PLACING CONCRETE. THE NUMBER OF DUCTS IS TO BE APPROVED BY THE SERVICE PLANNER/REGIONAL ENGINEER.
4. MAT FOUNDATION DESIGNED ASSUMING 1,000 PSF ALLOWABLE SOIL BEARING CAPACITY.
5. FOR GROUND ROD INSTALLATION DETAIL SEE 3-6-9.
6. FOR MINIMUM CLEARANCE TO OBSTRUCTION SEE 3-7-11.
7. FOR ANCHOR BOLT INSTALLATION DETAIL, SEE 3-6-10.
8. 1/2" TOP TO BOTTOM TAPER ALLOWED IN CONDUIT PLACEMENT OPENING.
9. PRIMARY CONDUIT MUST BE POSITIONED AT THE FRONT OF THE WINDOW.
10. TRANSFORMER AND PAD SELECTION ON SECONDARY METERED INSTALLATIONS ARE DETERMINED BY THE DTE PLANNER.

DTE ELECTRIC COMPANY ASSUMES NO RESPONSIBILITY FOR INJURY OR DAMAGE ARISING FROM THE USE OF THIS SPECIFICATION DIAGRAM.

CONCRETE TRANSFORMER PAD  
(SECONDARY METERED)

1-56-102B  
1-43-32.2B

WHEN USED FOR ISO PAD  
TRANSFORMER, 13.2 kV IS LEFT  
SIDE, 4.8kV IS RIGHT SIDE.

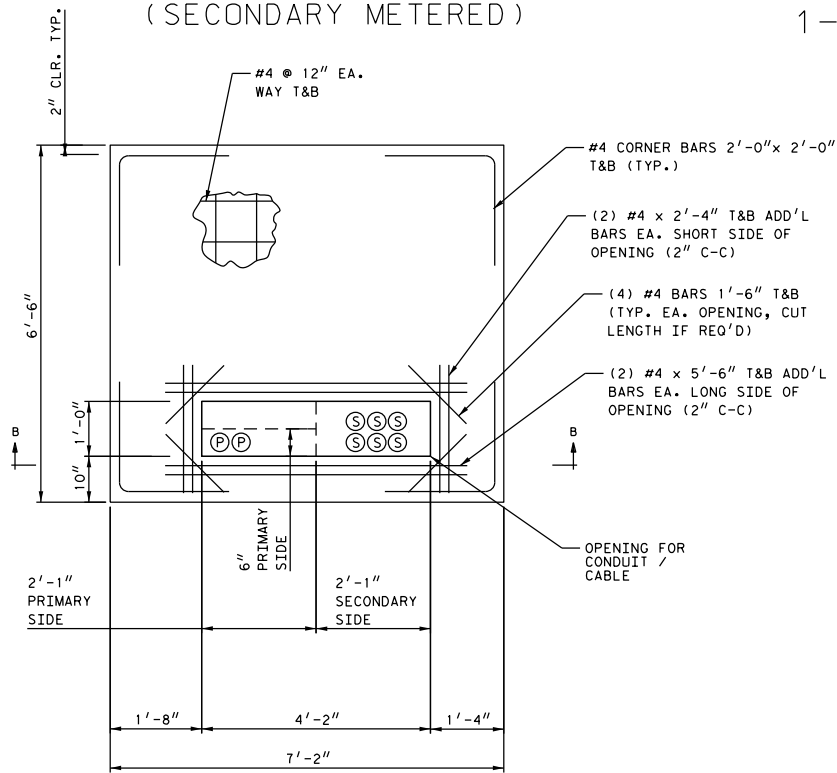

FOUNDATION PLAN VIEW

CONCRETE PAD FOR ALL THREE-PHASE NON-SWITCHING AND  
THREE-PHASE ISO PAD TRANSFORMERS 750 TO 1500 KVA

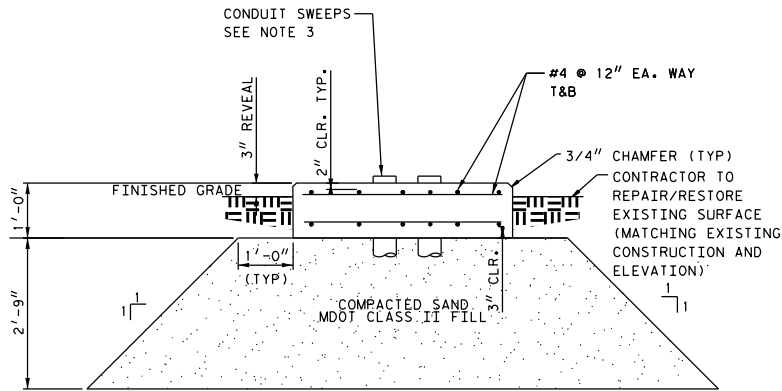

SECTION 'B-B'

NOTE: NOT TO SCALE.

NOTES:

1. THIS SPECIFICATION IS FOR PADS CAST IN PLACE OR PRECAST.
2. REFER TO 3-6-14 TO 3-6-15 FOR GENERAL NOTES.
3. FIELD TO LOCATE AND POSITION ALL CONDUIT SLEEVES FOR CABINETS PRIOR TO PLACING CONCRETE. THE NUMBER OF DUCTS IS TO BE APPROVED BY THE SERVICE PLANNER/REGIONAL ENGINEER.
4. MAT FOUNDATION DESIGNED ASSUMING 1,000 PSF ALLOWABLE SOIL BEARING CAPACITY.
5. FOR GROUND ROD INSTALLATION DETAIL SEE 3-6-9.
6. FOR MINIMUM CLEARANCE TO OBSTRUCTION SEE 3-7-11.
7. FOR ANCHOR BOLT INSTALLATION DETAIL, SEE 3-6-10.
8. 1/2" TOP TO BOTTOM TAPER ALLOWED IN CONDUIT PLACEMENT OPENING.
9. PRIMARY CONDUIT MUST BE POSITIONED AT THE FRONT OF THE WINDOW.
10. TRANSFORMER AND PAD SELECTION ON SECONDARY METERED INSTALLATIONS ARE DETERMINED BY THE DTE PLANNER.

DTE ELECTRIC COMPANY ASSUMES NO RESPONSIBILITY FOR INJURY  
OR DAMAGE ARISING FROM THE USE OF THIS SPECIFICATION DIAGRAM.

CONCRETE PAD FOR THREE-PHASE DEAD FRONT TRANSFORMERS 75-750 KVA WITH MULTIPLE SECONDARY TERMINATION CABINET

1-56-109  
1-43-32.5

NOTIFICATION TO SPECIFICATION PRACTICES IS REQUIRED WITH THE USE OF THIS CABINET PRIOR TO COMMITMENT TO A CUSTOMER.

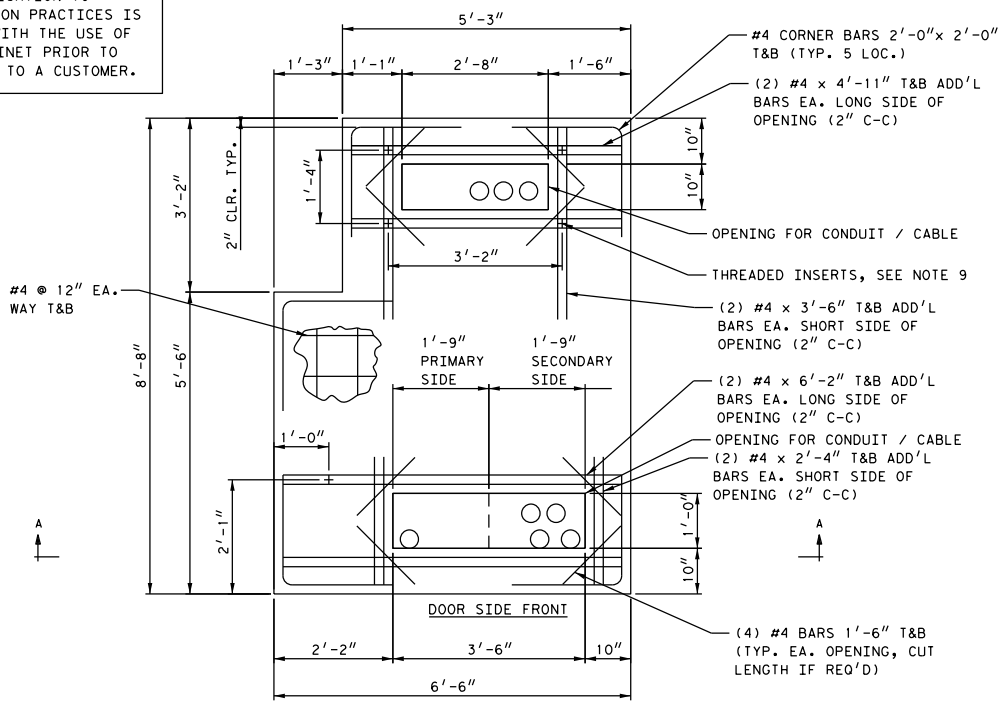

FOUNDATION PLAN VIEW

SEE SECTION 'A-A' FOR ADD'L REINFORCING.

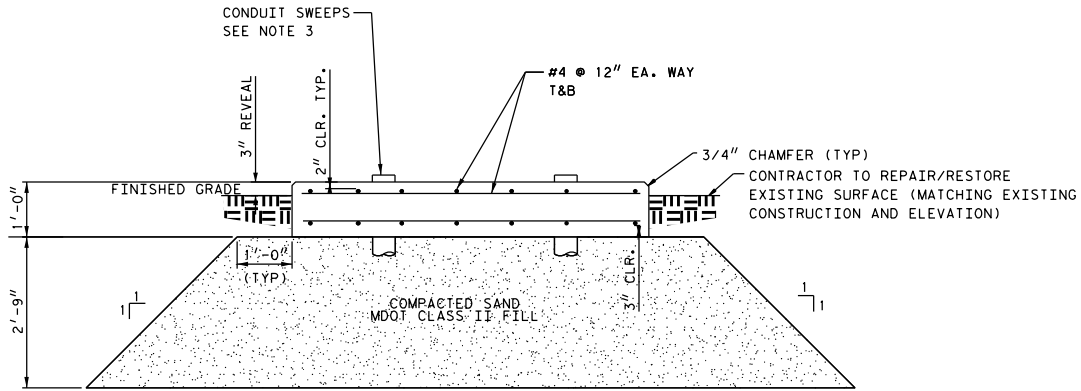

SECTION 'A-A'

NOTE: NOT TO SCALE.

NOTES:

1. THIS SPECIFICATION IS FOR PADS CAST IN PLACE OR PRECAST.
2. REFER TO 3-6-14 TO 3-6-15 FOR GENERAL NOTES.
3. FIELD TO LOCATE AND POSITION ALL CONDUIT SLEEVES FOR CABINETS PRIOR TO PLACING CONCRETE. THE NUMBER OF DUCTS IS TO BE APPROVED BY THE SERVICE PLANNER/REGIONAL ENGINEER.
4. MAT FOUNDATION DESIGNED ASSUMING 1,000 PSF ALLOWABLE SOIL BEARING CAPACITY.
5. FOR GROUND ROD INSTALLATION DETAIL SEE 3-6-9.
6. FOR MINIMUM CLEARANCE TO OBSTRUCTION SEE 3-7-11 THROUGH 3-7-12.
7. FOR ANCHOR BOLT INSTALLATION DETAIL, SEE 3-6-10.
8. 1/2" TOP TO BOTTOM TAPER ALLOWED IN CONDUIT PLACEMENT OPENING.
9. 5/8" THREADED CONCRETE INSERTS WITH CAL. CAP SCREWS, MIN. TENSION STRENGTH 12,000 LBS.

DTE ELECTRIC COMPANY ASSUMES NO RESPONSIBILITY FOR INJURY OR DAMAGE ARISING FROM THE USE OF THIS SPECIFICATION DIAGRAM.



CONCRETE PAD FOR  
MULTIPLE SECONDARY TERMINATION CABINET

1-56-109.1

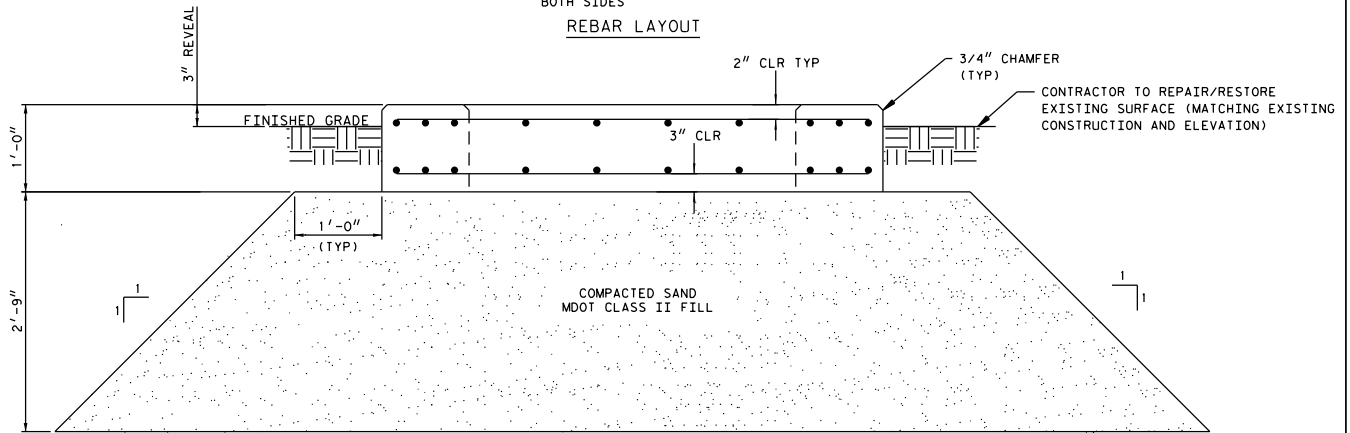
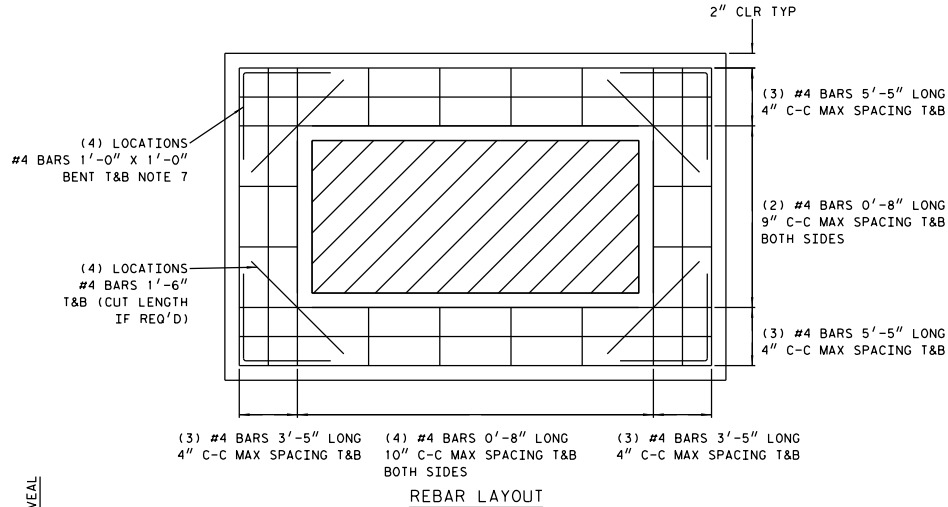
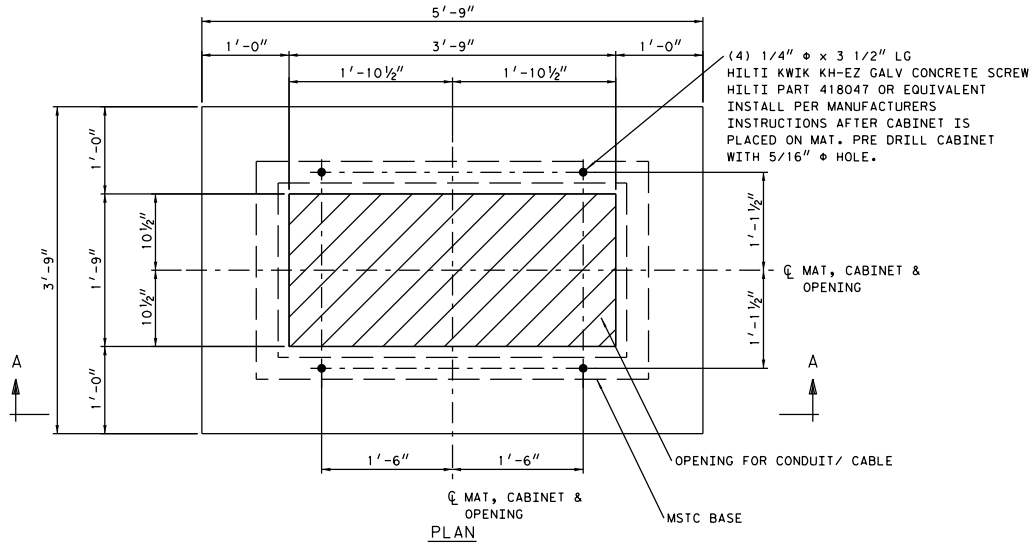

NOTES:

SECTION 'A-A'  
NOTE: NOT TO SCALE.

1. THIS SPECIFICATION IS FOR PADS CAST IN PLACE OR PRECAST.
2. REFER TO 3-6-14 TO 3-6-15 FOR GENERAL NOTES.
3. FIELD TO LOCATE AND POSITION ALL CONDUIT SLEEVES FOR CABINETS PRIOR TO PLACING CONCRETE. THE NUMBER OF DUCTS IS TO BE APPROVED BY THE SERVICE PLANNER/REGIONAL ENGINEER.
4. MAT FOUNDATION DESIGNED ASSUMING 1,000 PSF ALLOWABLE SOIL BEARING CAPACITY.
5. FOR GROUND ROD INSTALLATION DETAIL SEE 3-6-9.
6. FOR MINIMUM CLEARANCE TO OBSTRUCTION SEE 3-7-11 THROUGH 3-7-12.
7. FOR ANCHOR BOLT INSTALLATION DETAIL, SEE 3-6-10.
8. 1/2" TOP TO BOTTOM TAPER ALLOWED IN CONDUIT PLACEMENT OPENING.
9. IF DESIRED, 1'-0" LEGS CAN BE BENT INTO THE HORIZONTAL REBAR INSTEAD OF SEPARATE CORNER BARS.

DTE ELECTRIC COMPANY ASSUMES NO RESPONSIBILITY FOR INJURY OR DAMAGE ARISING FROM THE USE OF THIS SPECIFICATION DIAGRAM.

GROUNDING FOR CUSTOMER INSTALLED PAD

1-15-202

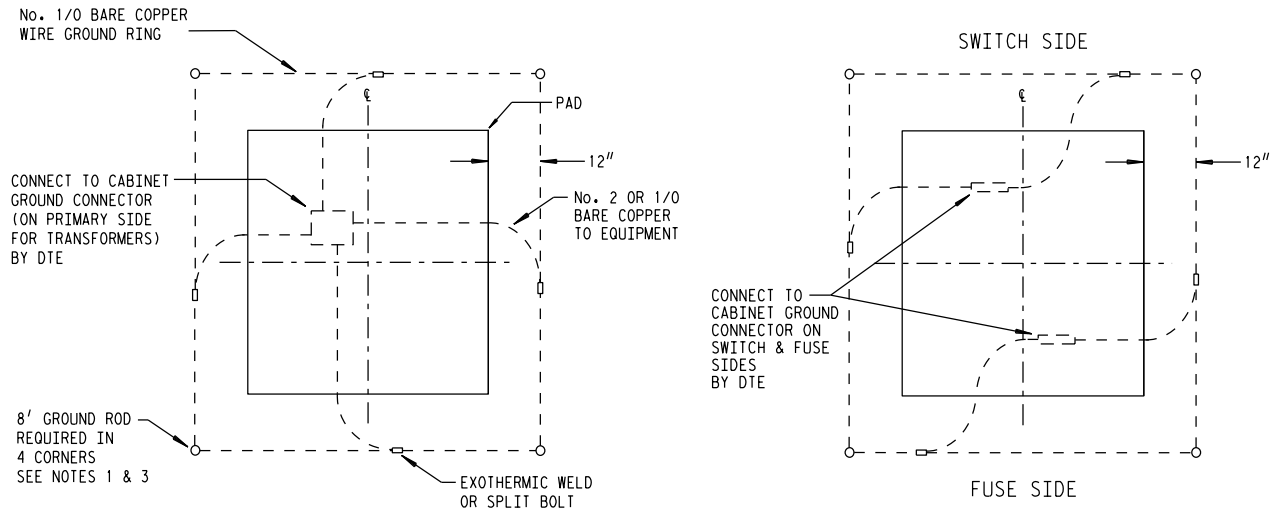

TRANSFORMER, SCC, OR FSS LOCATION

NOTE: NOT TO SCALE

PRIMARY SWITCH CABINET LOCATION

NOTE: NOT TO SCALE

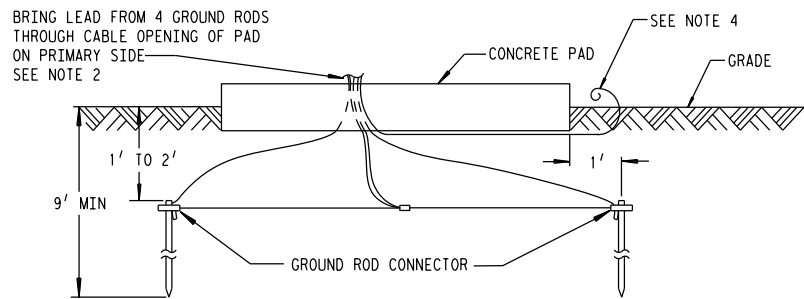

NOTE: NOT TO SCALE

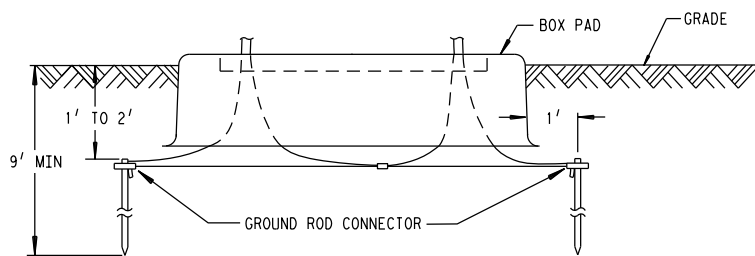

NOTE: NOT TO SCALE

NOTES:

1. MAY BE ACCOMPLISHED USING (1) 8' GROUND ROD OR (2) 4' GROUND RODS WITH COUPLER.
2. 7' OF GROUND WIRE SHALL BE EXTENDED ABOVE SURFACE OF PAD TO CONNECT TO EQUIPMENT.
3. GROUNDS SHALL BE RESISTANCE TESTED TO BE 15 OHMS OR LESS. IF TESTED ABOVE 15 OHMS, ROD(S) SHALL BE DRIVEN DEEPER AND ADDITIONAL EXTENSION ROD(S) SHALL BE COUPLED ON TOP UNTIL PROPER RESISTANCE IS MEASURED.
4. DTE TO FURNISH AND LEAVE 20' BARE NO. 6 GROUND WIRE FOR THE TELEPHONE UTILITY TO BOND THEIR NON-JOINT PEDESTALS THAT ARE WITHIN 20' OF A PAD. THEY MUST REQUEST THE GROUND WIRE AT THE ENGINEERING MEETING FOR REAR LOT CONSTRUCTION. FOR FRONT LOT CONSTRUCTION, IT IS TO BE INSTALLED AT ALL TRANSFORMERS.

DTE ELECTRIC COMPANY ASSUMES NO RESPONSIBILITY FOR INJURY OR DAMAGE ARISING FROM THE USE OF THIS SPECIFICATION DIAGRAM.

CONCRETE PAD POSTS

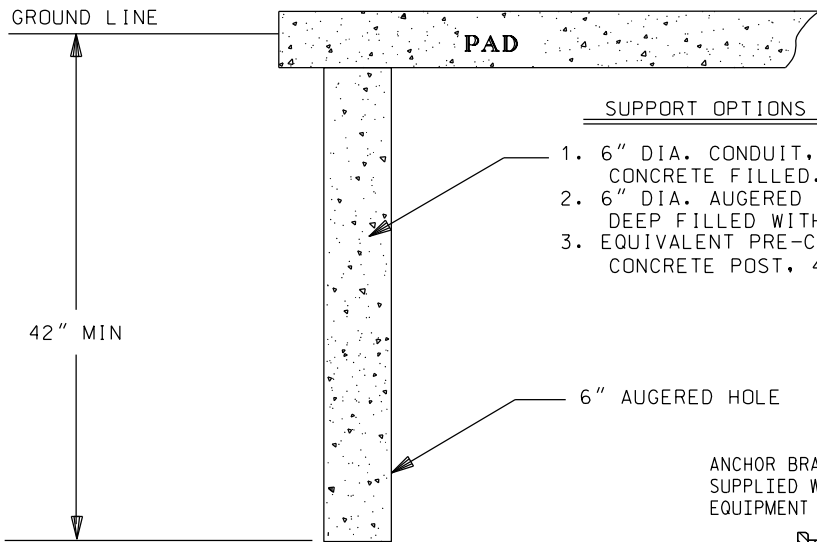

SUPPORT OPTIONS

1. 6" DIA. CONDUIT, 42" MIN LONG, CONCRETE FILLED.
2. 6" DIA. AUGERED HOLE, 42" MIN DEEP FILLED WITH CONCRETE.
3. EQUIVALENT PRE-CAST CONCRETE POST, 42" MIN LONG.

6" AUGERED HOLE

SUPPORT POST

NOTE: USE ONLY IF REQUIRED DUE TO POOR SOIL CONDITIONS. CONTACT DTE ENGINEERING STANDARDS PRIOR TO USE.

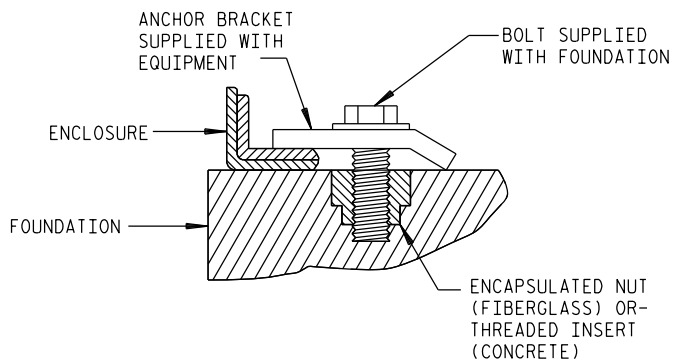

ANCHOR BOLT WITH THREADED INSERT

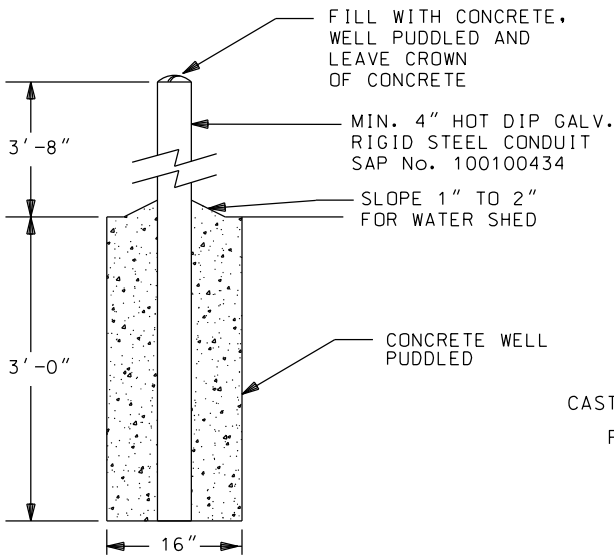

GUARD POST

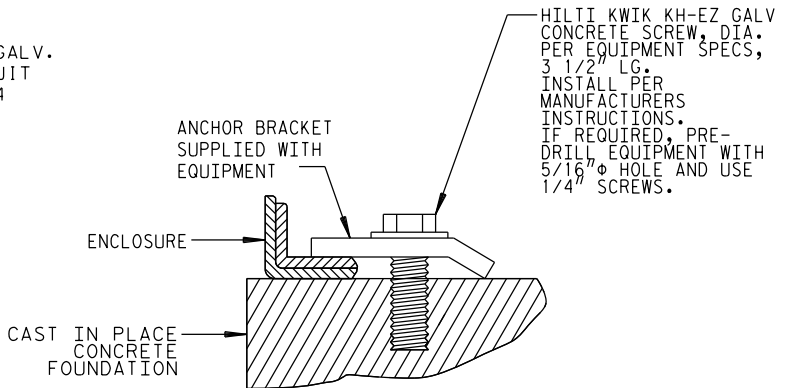

POST-INSTALLED ANCHOR

NOTE: CONTRACTOR TO INSTALL GUARD POSTS WHERE PADMOUNT EQUIPMENT IS EXPOSED TO TRAFFIC. SPACE POSTS 3 TO 5 FEET APART WITH 2 FEET MINIMUM CLEARANCE TO PAD. POSTS MUST NOT BE LOCATED IN FRONT OF EQUIPMENT DOORS NOR INTERFERE WITH THE SWING OF DOORS.

DTE ELECTRIC COMPANY ASSUMES NO RESPONSIBILITY FOR INJURY OR DAMAGE ARISING FROM THE USE OF THIS SPECIFICATION DIAGRAM.

TWO SINGLE PHASE TRANSFORMERS FOR DUPLEX CONNECTION

\* LIMITED USE - CONSULT SERVICE PLANNER

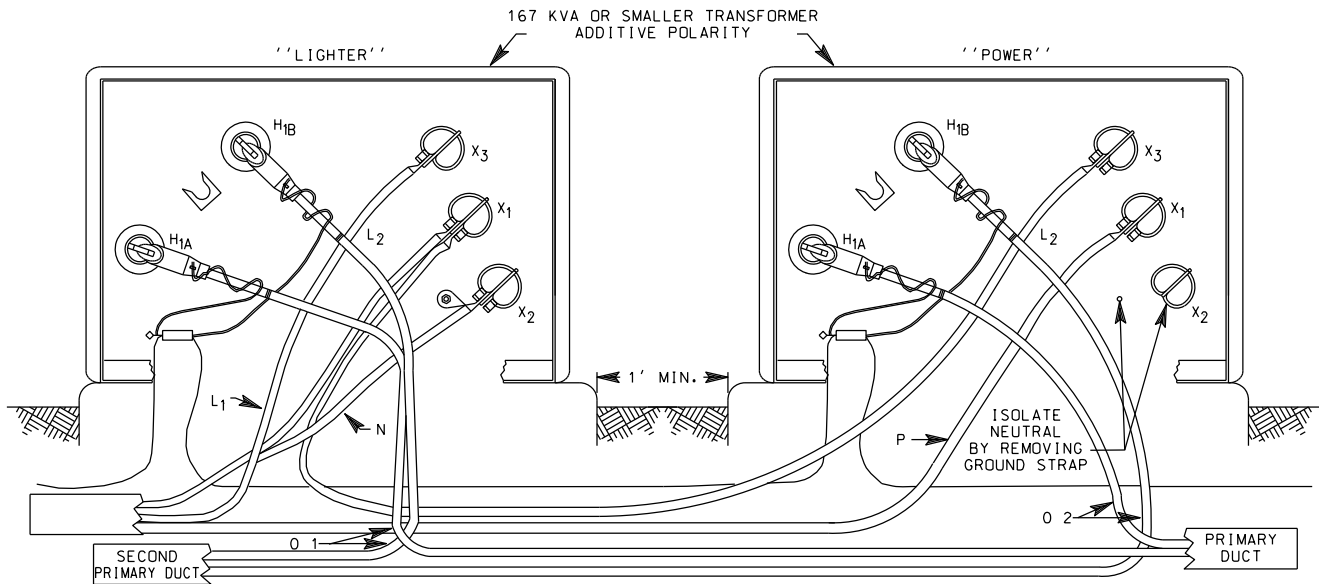

NOTES:

1. DO NOT DETAIL ESTIMATE (HAND ORDER-PR 21).
  2. FOR FIELD CONNECTION REFER TO UG LINE CONSTRUCTION STANDARDS MANUAL, PAGE 1-17-225. (INDICATE ADDITIVE OR SUBRACTIVE)
  - \* 3. BOX PAD FURNISHED AND INSTALLED BY CUSTOMER.
  4. CONDUIT FURNISHED AND INSTALLED BY CUSTOMER.
  5. SECONDARY CABLES FURNISHED AND INSTALLED BY CUSTOMER AND TERMINATED BY DTE.
  6. PRIMARY CABLES FURNISHED AND INSTALLED BY DTE.
  7. FOR 25 KVA TRANSFORMERS, ROTATE FOUNDATION 90° TO ASSURE OPENING WILL BE COVERED BY TRANSFORMER.
- \* CONSULT MATERIAL COORDINATOR D-241 WSC FOR APPROVED SUPPLIERS.

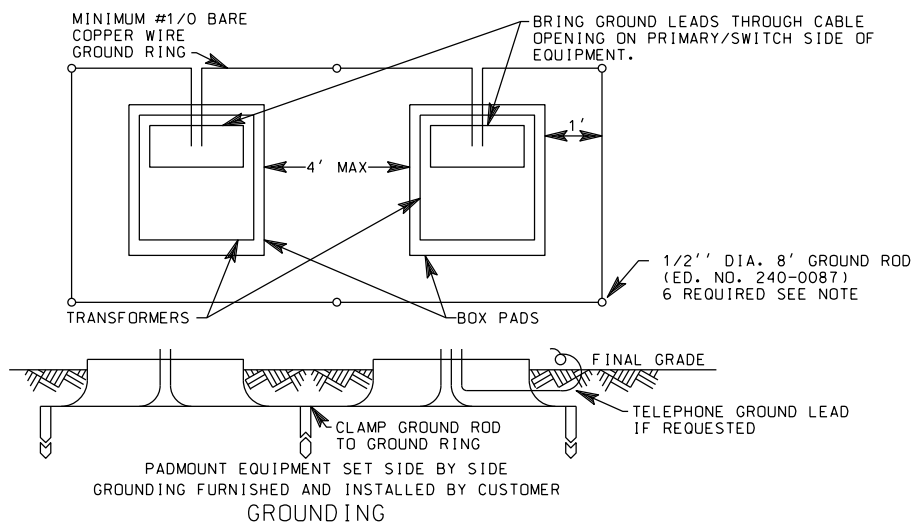

250 KVA TRANSFORMER SUBSTRACTIVE POLARITY

167 KVA OR SMALLER TRANSFORMER-ADDITIVE POLARITY

NOTE:

A 5/8" DIA. X 8' LG COPPER CLAD GROUND ROD WITH CLAMP. (ANDERSON ELECTRIC GC-103-02 EQUIVALENT IS AN ACCEPTABLE ALTERNATIVE)

DTE ELECTRIC COMPANY ASSUMES NO RESPONSIBILITY FOR INJURY OR DAMAGE ARISING FROM THE USE OF THIS SPECIFICATION DIAGRAM.

GLASS FIBER REINFORCED CONCRETE BOX PAD

- 1) ALL SØ TRANSFORMERS EXCEPT 4.8 KV SWITCHING (1 REQUIRED)
- 2) SØ MINI-PAD DUPLEX CONFIGURATION (SHOWN BELOW - 2 REQUIRED)

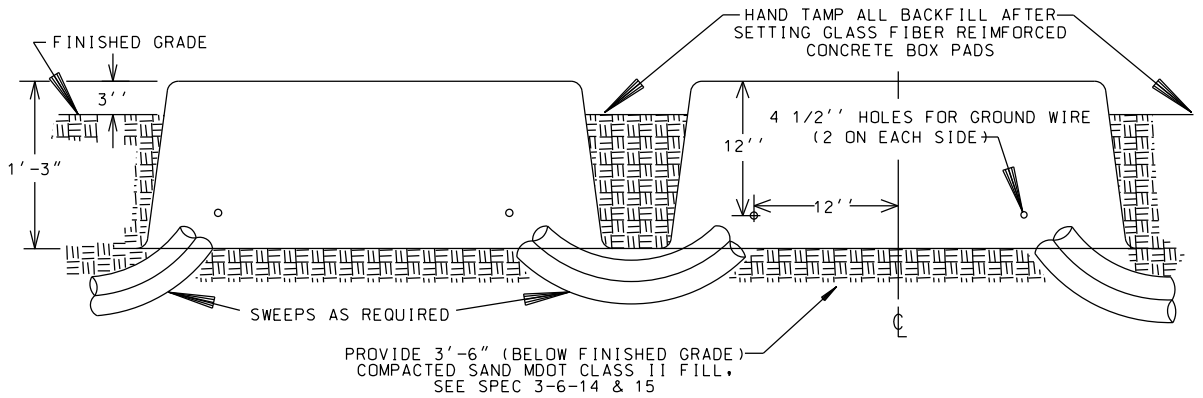
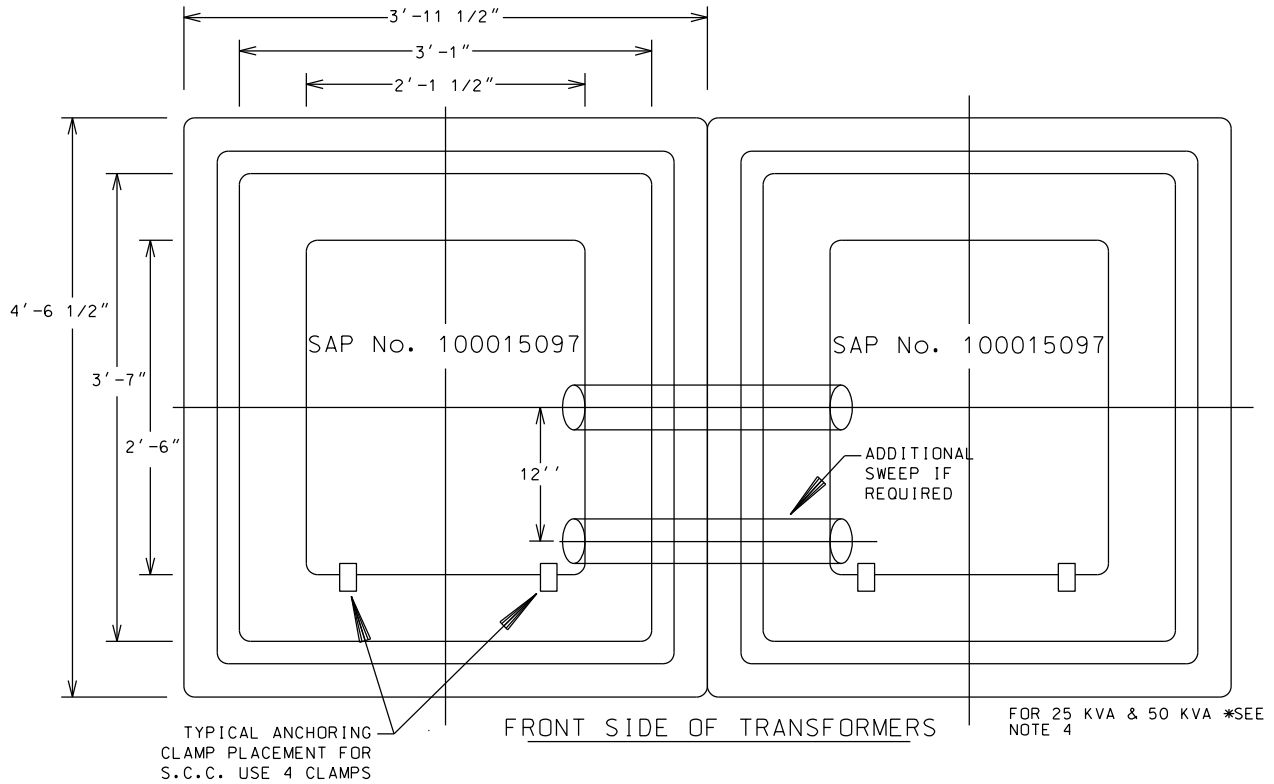

NOTES

1. FOR GROUNDING DETAILS SEE SPECS 3-6-9 & 3-6-12.
2. THE NUMBER AND LOCATION OF DUCTS IS TO BE APPROVED BY SERVICE PLANNER.
3. FOR MINIMUM CLEARANCE TO OBSTRUCTIONS SEE SPECS 3-7-11 & 12.
4. FOR 25 KVA & 50 KVA TRANSFORMERS, ROTATE FOUNDATION 90° TO ASSURE OPENING WILL BE COVERED BY TRANSFORMER.
5. FOR CURRENT BOX PAD SUPPLIER INFORMATION, SERVICE PLANNERS SHOULD CONTACT MATERIAL COORDINATOR D-241 WSC.
6. FOR INSTALLATION GUIDELINES SEE SPEC PG 3-16-14 & 15.

DTE ELECTRIC COMPANY ASSUMES NO RESPONSIBILITY FOR INJURY OR DAMAGE ARISING FROM THE USE OF THIS SPECIFICATION DIAGRAM.

Foundation Installation – Excavation, Compacted Fill, Backfilling

These requirements apply to all underground line equipment foundation construction, including box pad, cast in place, and pre-cast foundations.

A. Excavation Requirements

- (i) Excavation shall be to a depth that will permit preparation of a foundation as specified or installation of the box pad at prescribed depth, but at a minimum, shall be 3’-6” below finished grade. The width and length of the excavated hole shall be sufficient to permit the foundation and compacted fill installation, as specified below.
- (ii) All excavations shall be kept free of standing water, frost, snow, ice, and foreign debris. No foundations shall be set against water, frost, snow, or ice.

B. Compacted Fill Requirements

- (i) All foundations, including box pad, cast in place, and pre-cast, shall be laid on compacted sand (MDOT Class II fill). Fill shall extend to 3’-6” below finished grade. At the base of the foundation, fill shall extend 1’-0” beyond the plan dimensions of the foundation, on all sides. Fill shall be distributed to 3’-6” below finished grade at a 1:1 ratio. See sketch below.
- (ii) Minimum soil bearing capacity is assumed to be 1000 psf. In cases where adequacy of the base may be doubtful, DTE may require bearing capacity tests results from a qualified testing laboratory.
- (iii) When conditions such as unstable soil, frozen backfill, or rock are encountered, special action must be taken to provide a sound soil base for the entire foundation. The decision for correction of an overall poor condition such as swampy land or general regrading should be made by the division engineer.

C. Backfilling Requirements

- (i) All foundation excavations shall be backfilled with suitable material and compacted to the final grade as specified. Suitable material shall be lean grout fill (see 3-6-15), MDOT Class II fill (compacted sand), or mineral soil reasonably free of foreign materials, rubbish, debris, etc. Backfill shall be free of frozen clumps, oversized stone, rock or concrete, bituminous chunks or other unsuitable materials that may damage the foundations.
- (ii) Backfill in 9” maximum lifts and compact well. Compaction of backfill materials placed within the foundation openings can be accomplished with portable or hand equipment methods.
- (iii) The top surface shall be restored to match existing elevation and existing construction type.

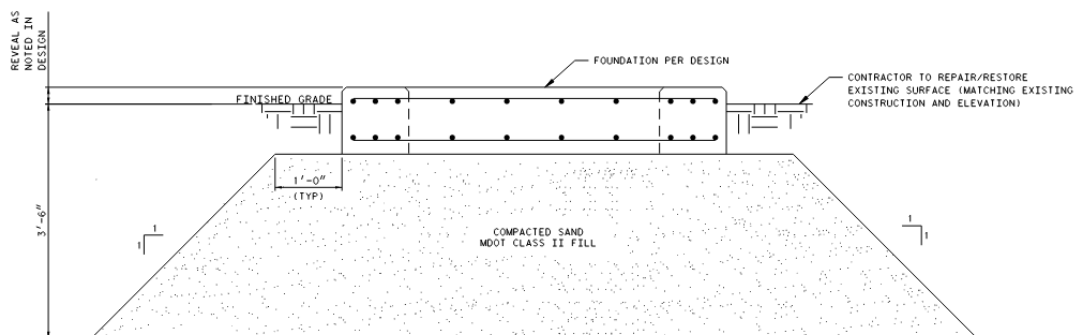

SECTION VIEW

Foundation Installation – Excavation, Compacted Fill, Backfilling  
(Continued)

- D. Installations near existing buildings, structures, or sidewalks:
- (i) If the edge of a foundation pad is within 4'-0" of an existing building or structure or within 7'-0" of an existing sidewalk edge, follow this procedure to install base fill near the adjacent foundation/sidewalk.
  - (ii) Maintain all minimum clearances as noted in Section 11.
  - (iii) Along the edge adjacent to the building or structure, drive 2x4 or 2x6 wood timbers approximately 1'-1" from the edge of the future foundation pad.
  - (iv) Timber driving and excavation may be done in stages. It is recommended to maintain the base of wood timbers at least 6" below the base of excavation at all times.
    - a. For example, drive timber down 1'-0" below grade. Excavate 6" of soil. Drive timber another 1'-0". Excavate another 1'-0" of soil. Continue until final depth of excavation is reached.
  - (v) Base of timbers shall be 4'-0" below finished grade, minimum.
  - (vi) Compacted base fill shall be installed as directed. On edges which are not adjacent to existing building or structures, base fill shall be installed as normally specified.
  - (vii) Install foundation as specified.
  - (viii) Install grounding rods as specified. Ground rods should be between the wood timbers and the foundation on edges near to existing buildings or structures.
  - (ix) Wood timbers may be removed prior to final backfill and surrounding grade restoration. Wood timbers may also be left in place, provided they are flush with surrounding grade and do not present a tripping hazard.

Foundation Installation – Excavation, Compacted Fill, Backfilling  
(Continued)

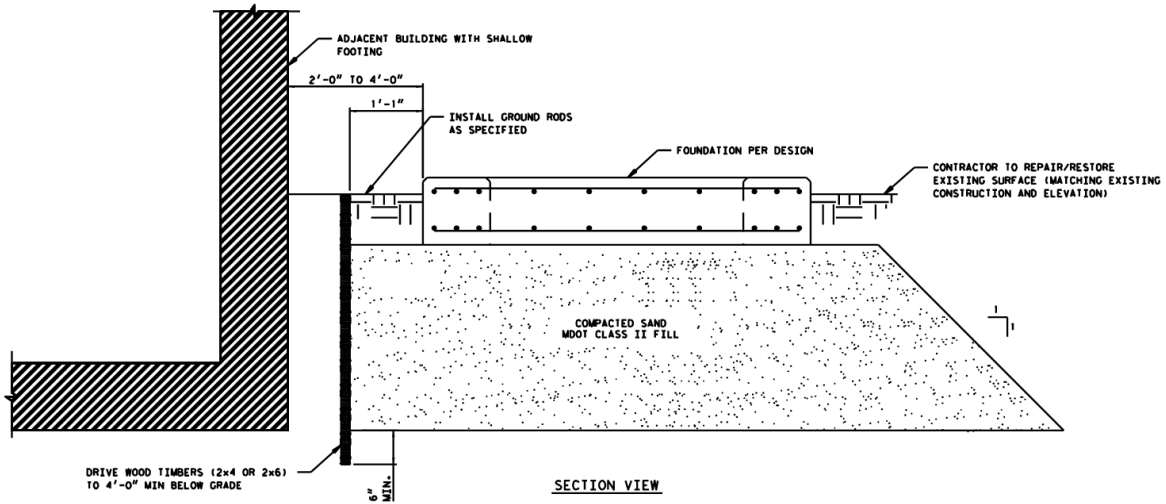

INSTALLATION NEAR EXISTING BUILDING OR STRUCTURE

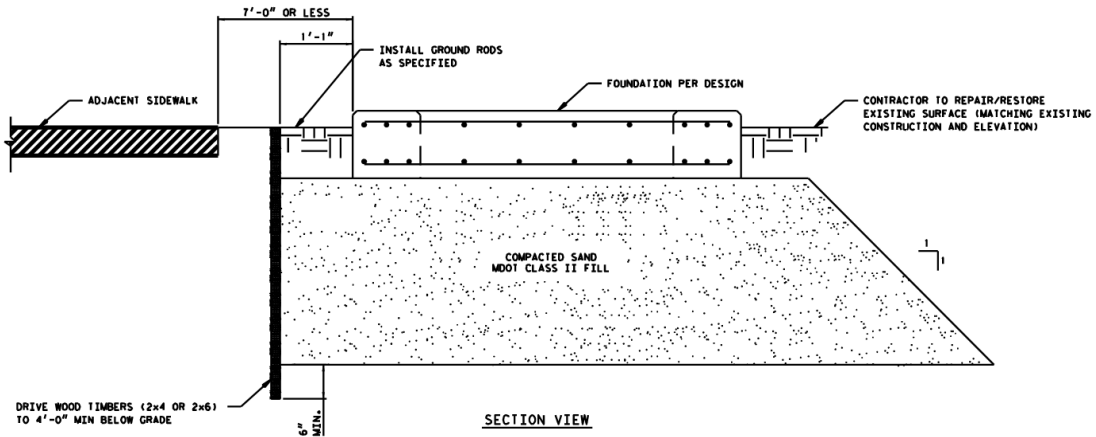

INSTALLATION NEAR EXISTING SIDEWALK



### Foundation Installation – Concrete Work

These guidelines are intended to be applicable to all cast in place underground line equipment foundation construction.

#### A. Concrete Mix Requirements

- (i) Minimum compressive strength of concrete at 28 days: 4500 psi (unless noted otherwise).
- (ii) Use only type I, II, III or IL cement (unless noted otherwise). Contact the DTE civil engineer if types II or III is selected.
- (iii) Provide 5½% +/- 1% entrained air, water cement ratio: 0.45 and a slump of 4" to 6" (unless noted otherwise). Add water reducing admixtures as required to achieve required slump.

#### B. Placing and Finishing Concrete

- (i) Provide a float finish on all horizontal surfaces (unless noted otherwise).
- (ii) Provide a 3/4" chamfer on all exposed edges of mats.
- (iii) Place concrete directly against sides of augered excavations. Use sonotube or other approved forms for top 24" of pier (at minimum).
- (iv) Provide top surface elevations of piers and mats 3" above finished grade (unless noted otherwise).
- (v) Cold weather concrete placement – conform to ACI 306R (latest revision) requirements.
- (vi) Hot weather concrete placement – conform to ACI 305R (latest revision) requirements.
- (vii) Place all embedded items (such as anchor bolts, pipe sleeves, etc) accurately and secure prior to concrete placement.
- (viii) Consolidate concrete during placement by use of an adequate number of internal type vibrators.

#### C. Curing Concrete

- (i) Cure all concrete per ACI 308R for a minimum period of (7) seven days.
- (ii) Keep concrete moist while forms are in place.
- (iii) Once forms are removed use an approved ASTM C309 Type 2 Class A liquid membrane curing compound at approximately 1 gallon per 150 sq ft of coverage or as specified by manufacturer.

#### D. Reinforcing Steel

- (i) Reinforcing bars, stirrups, and ties shall be ASTM A615 Grade 60 deformed bars.
- (ii) Provide splices only where shown on drawings with minimum lap length as specified (not less than 12"). If no lap length is given, provide minimum ACI standard lap lengths.
- (iii) Use black annealed tie-wire, 18 ga or heavier wire for fastening. No welding or torch cutting of rebar is permitted.
- (iv) Maintain minimum 1½" clearance between reinforcing steel and form ties, inserts, embedments, etc. Maintain 3" steel to soil clearance, and 2" steel to form clearance where not exposed to soil.

#### E. Lean Grout Fill

Lean grout fill mixes shall consist of the following (unless noted otherwise):

- (i) 3550lbs of MDOT 2NS (Sect 902.08) fine aggregate per cubic yd.
- (ii) 190 lbs of cement per cubic yd.
- (iii) 250lbs +/- of water per cubic yd. Adjust water depending on fill application.

MINIMUM CLEARANCE REQUIREMENTS FOR 13.2 KV  
OR 4.8 KV TRANSFORMER OR SWITCH CABINET FOUNDATION LOCATION

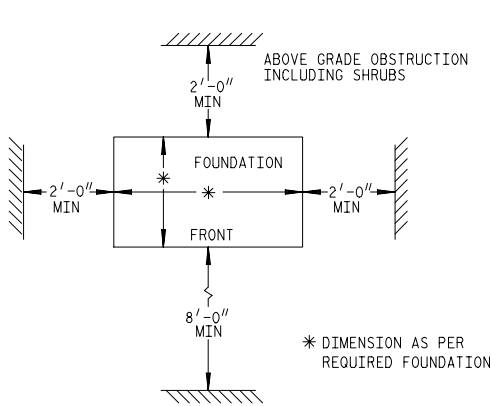

1  $\phi$  & 3  $\phi$  DEAD FRONT TRANSFORMER  
1  $\phi$  & 3  $\phi$  SWITCHING TRANSFORMER  
3  $\phi$  SEPARABLE CONNECTION CABINET  
DETAIL 11211A

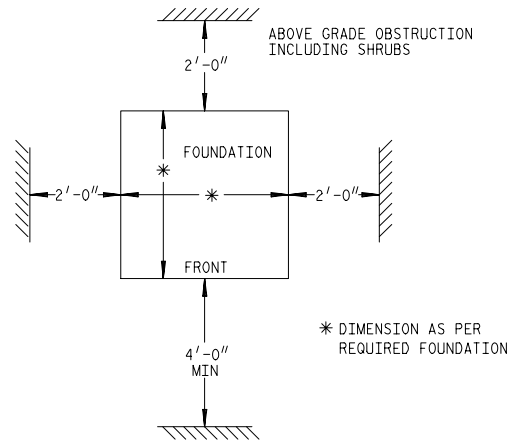

1  $\phi$  & 3  $\phi$  NON-SWITCHING TRANSFORMER  
LIVE FRONT  
DETAIL 11211B

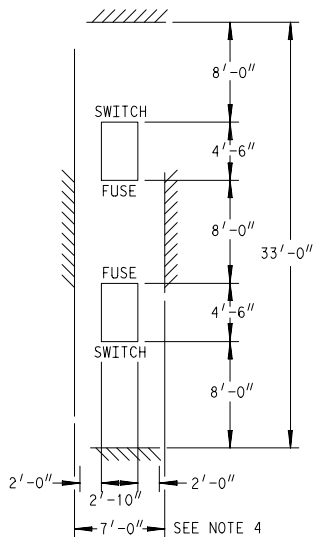

MODEL 5 CABINETS  
FUSE END TO FUSE END  
DETAIL 11211C

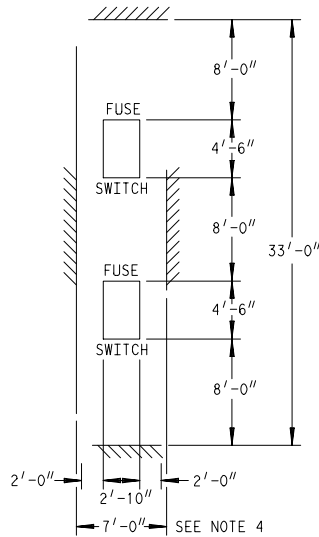

MODEL 5 CABINETS  
FUSE END TO SWITCH END  
DETAIL 11211D

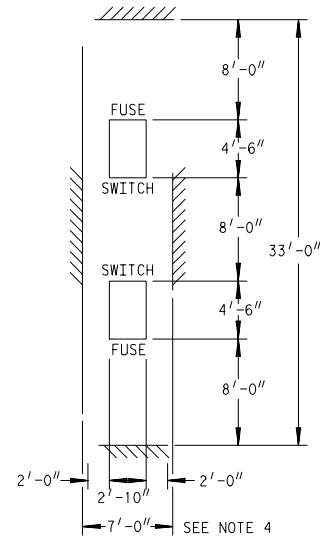

MODEL 5 CABINETS  
SWITCH END TO SWITCH END  
DETAIL 11211E

GENERAL NOTES:

1. PLACEMENT OF EQUIPMENT UNDER OVERHANGS SHOULD BE AVOIDED. A VERTICAL CLEARANCE OF 12' IS REQUIRED FROM TOP OF SWITCH CABINET TO ANY OVERHANG.
2. FENCE OR WALL AROUND TRANSFORMER MUST HAVE 5'-0" MIN GATE FOR CHANGE OUT.
3. FOR CUSTOMER OWNED INSTALLATIONS SEE NATIONAL ELECTRIC CODE 450-27.
4. OVERALL EASEMENT DIMENSIONS ARE GIVEN TO NEAREST HALF-FOOT.
5. CLEARANCE AREA MUST BE LEVEL AND FREE OF OBSTRUCTIONS FOR OPERATING REQUIREMENTS.

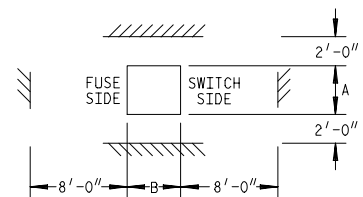

PMH SWITCH CABINETS  
DETAIL 11211F

STYLE	A	B
MODEL 6,8,9 & 11	5'-7"	5'-1"
MODEL 5	2'-10"	4'-6"

DTE ELECTRIC COMPANY ASSUMES NO RESPONSIBILITY FOR INJURY OR DAMAGE ARISING FROM THE USE OF THIS SPECIFICATION DIAGRAM.

MINIMUM CLEARANCE REQUIREMENTS  
FOR TRANSFORMER WITH MSTC FOUNDATION LOCATION

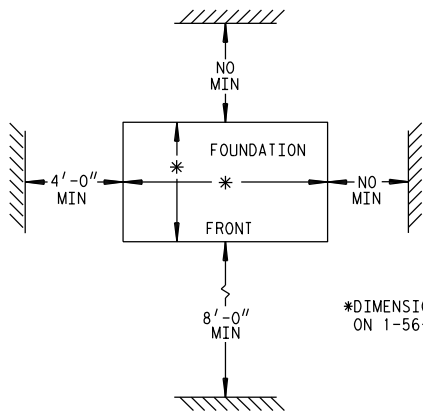

\*DIMENSIONS AS PER FOUNDATION  
ON 1-56-124 OR 1-56-125

2-WAY 3Φ  
FEEDER SECTION SWITCH  
DETAIL 11211G

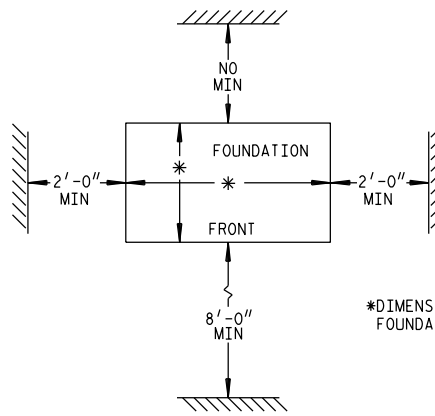

\*DIMENSIONS AS PER  
FOUNDATION ON 1-56-123

3-WAY 3Φ  
FEEDER SECTION SWITCH  
DETAIL 11211H

NOTES:

1. PLACEMENT OF EQUIPMENT UNDER OVERHANGS SHOULD BE AVOIDED. A VERTICAL CLEARANCE OF 12' IS REQUIRED FROM TOP OF SWITCH CABINET TO ANY OVERHANG.
2. FOR CUSTOMER OWNED INSTALLATIONS SEE NATIONAL ELECTRIC CODE 450-27.
3. CLEARANCE AREA MUST BE LEVEL AND FREE OF OBSTRUCTIONS FOR OPERATING REQUIREMENTS.

DTE ELECTRIC COMPANY ASSUMES NO RESPONSIBILITY FOR INJURY OR DAMAGE ARISING FROM THE USE OF THIS SPECIFICATION DIAGRAM.

MINIMUM CLEARANCE REQUIREMENTS FOR 13.2 KV  
OR 4.8 KV G&W SWITCH CABINET FOUNDATION LOCATION

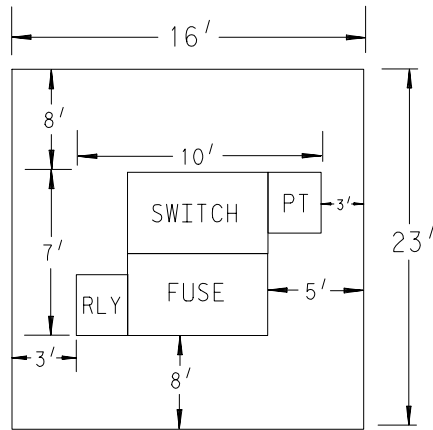

DETAIL 11211I

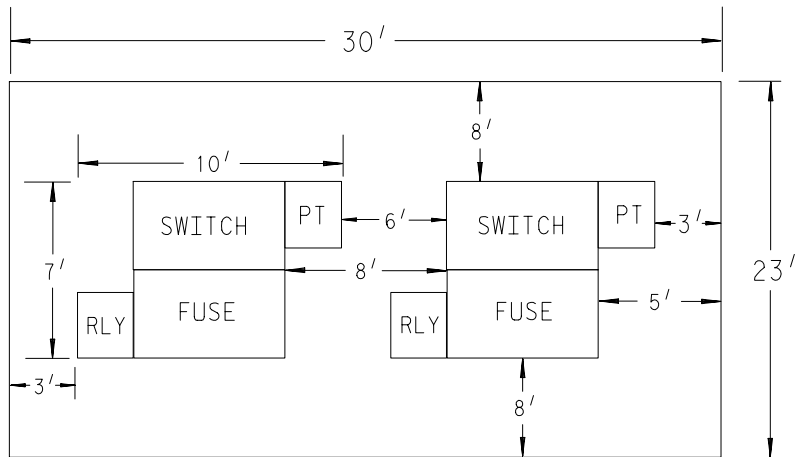

DETAIL 11211J

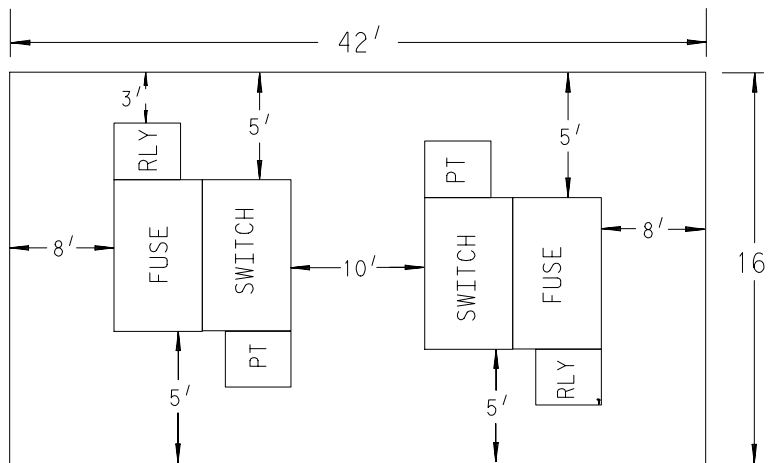

DETAIL 11211K

DTE ELECTRIC COMPANY ASSUMES NO RESPONSIBILITY FOR INJURY  
OR DAMAGE ARISING FROM THE USE OF THIS SPECIFICATION DIAGRAM.

MINIMUM CLEARANCE REQUIREMENTS  
FOR TRANSFORMER WITH MSTC FOUNDATION LOCATION

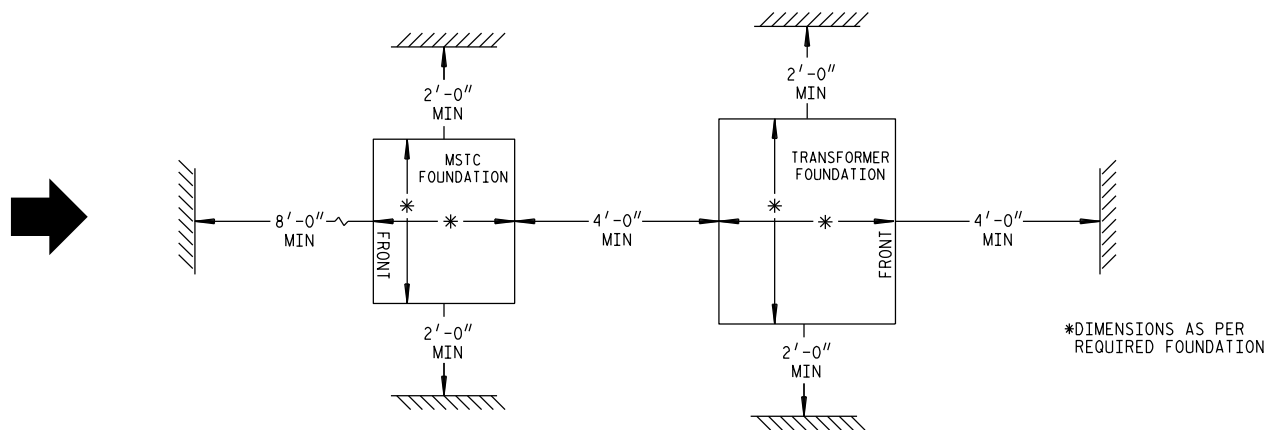

DEAD FRONT TRANSFORMER  
WITH MULTIPLE SECONDARY TERMINATION CABINET  
DETAIL 11211L

**NOTES:**

1. FENCE OR WALL AROUND TRANSFORMER MUST HAVE 5'-0" MIN GATE FOR CHANGE OUT.
2. FOR CUSTOMER OWNED INSTALLATIONS SEE NATIONAL ELECTRIC CODE 450-27.

DTE ELECTRIC COMPANY ASSUMES NO RESPONSIBILITY FOR INJURY  
OR DAMAGE ARISING FROM THE USE OF THIS SPECIFICATION DIAGRAM.

1-11-212

MINIMUM CLEARANCE REQUIREMENTS FOR 13.2 KV OR 4.8 KV PAD MOUNTED PRIMARY SWITCHING CABINETS (PSC)

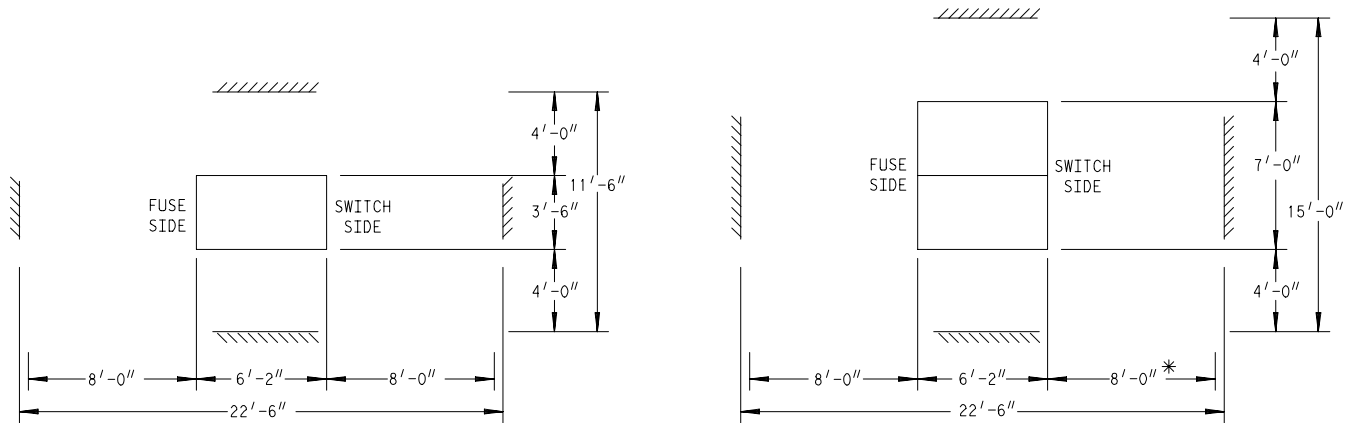

LOW PROFILE CABINET  
DETAIL 11212A

2 - LOW PROFILE CABINETS BOLTED TOGETHER  
DETAIL 11212B

\* EXTRA CLEARANCE REQUIRED WHEN BOTH SWITCH DOORS ARE OPEN

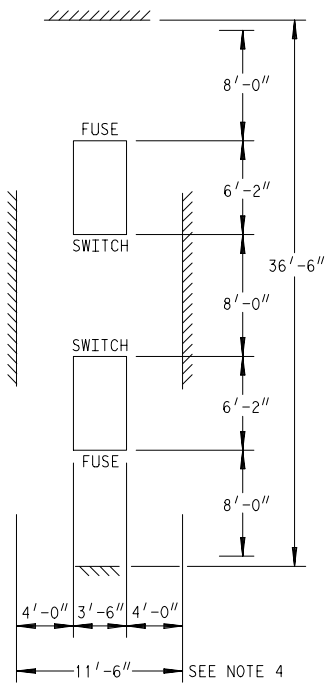

LOW PROFILE CABINET  
SWITCH END TO SWITCH END  
DETAIL 11212C

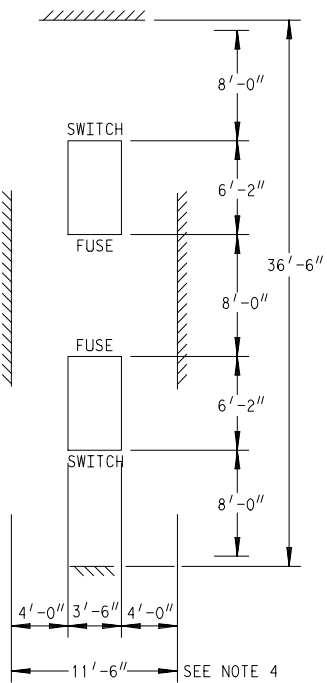

LOW PROFILE CABINET  
FUSE END TO FUSE END  
DETAIL 11212D

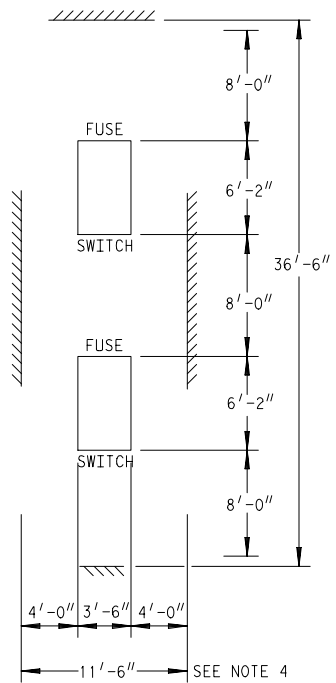

LOW PROFILE CABINET  
FUSE END TO SWITCH END  
DETAIL 11212E

GENERAL NOTES:

1. PLACEMENT OF EQUIPMENT UNDER ANY OVERHANG SHOULD BE AVOIDED.  
A VERTICAL CLEARANCE OF 12' IS REQUIRED FROM TOP OF TRANSFORMER OR SWITCH CABINET TO ANY OVERHANG.
2. FENCE OR WALL AROUND TRANSFORMER MUST HAVE 5'-0" MIN GATE FOR CHANGE OUT.
3. FOR CUSTOMER OWNED INSTALLATIONS SEE NATIONAL ELECTRIC CODE 450-27.
4. OVERALL EASEMENT DIMENSIONS ARE GIVEN TO NEAREST HALF-FOOT.

DTE ELECTRIC COMPANY ASSUMES NO RESPONSIBILITY FOR INJURY OR DAMAGE ARISING FROM THE USE OF THIS SPECIFICATION DIAGRAM.

## UNDERGROUND CLEARANCES FROM SWIMMING POOLS

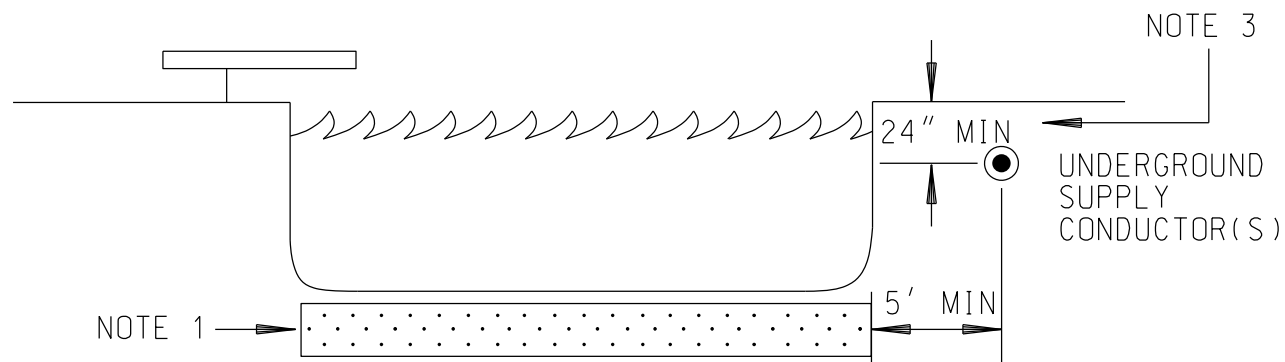
NOTES:

1. UNDERGROUND WIRING SHALL NEVER BE PERMITTED UNDER POOLS.
2. A MINIMUM DISTANCE OF 5 FT. SHALL EXIST BETWEEN ANY UNDERGROUND SUPPLY CONDUCTOR(S) AND THE INSIDE WALL OF THE POOL IN COMPLIANCE WITH NEC ARTICLE 680.10 AND NESC 351(C)(1).
3. UNDERGROUND SUPPLY CONDUCTORS SHALL HAVE A MINIMUM COVER OF 24 INCHES. SEE PAGE 3-4-1.
4. WHERE SPACE LIMITATIONS PREVENT WIRING FROM BEING ROUTED A DISTANCE OF 5 FT. OR MORE FROM THE POOL, SUCH WIRING SHALL BE PERMITTED WHERE INSTALLED IN RIGID METAL CONDUIT, INTERMEDIATE METAL CONDUIT, OR A NONMETALIC SCH 40 PVC.
5. FOR OVERHEAD CLEARANCES AROUND POOLS REFER TO 4-4-5.1

THE DTE ELECTRIC COMPANY ASSUMES NO RESPONSIBILITY FOR INJURY OR DAMAGE ARISING FROM THE USE OF THIS SPECIFICATION DIAGRAM.

PRECONSTRUCTION METER MOUNT**1. General.**

As an accommodation to the builder or developer, DTE Electric will allow an underground service to be installed to a preconstruction meter mount fastened to the foundation or basement wall before construction of the building framework. The preconstruction meter mount (PCM) will be the permanent support for the meter on the completed building and should satisfy the following conditions:

- (a) Installation safety.
- (b) Standard service requirements.
- (c) Ease of service installation and maintenance.
- (d) Protection of service conductors and proper operation of metering equipment during and after building construction.

The electrical contractor responsible for the PCM installation must review the plans with the DTE Electric Planner *before* installation begins. The contractor must also comply with the requirements of state or municipal inspectors. DTE Electric offers the following specifications as a guide for PCM installations:

**2. Manufactured or Fabricated PCM Assemblies.**

- (a) **Accepted by System Equipment and Engineering.** DTE Electric OH & UG Construction Standards must accept manufactured or fabricated PCM assemblies *before* installation in the DTE Electric service area. (See page 3-12-3 for acceptable units.)
- (b) **Specifications.** Distributors, representatives, or fabricators are required to supply specifications and make a unit available for inspection by the OH & UG Construction Standards Group.
- (c) **UL Listed.** Power outlet cabinets must have UL labels and have a weatherproof rating (NEMA 3R). Outlets must be GFCI protected.

**3. Meter Enclosures.**

DTE Electric allows the 1  $\Phi$  CL 200, 1  $\Phi$  CL 320, or 1  $\Phi$  CL 200 2 position horizontal meter enclosure to be mounted to the PCM. No other meter enclosures or arrangement for connecting the meter will be accepted. Customers are responsible for obtaining and installing enclosures. For a list of approved enclosure vendors refer to Section 5-8.

- NOTE: Any bond between the meter enclosure and joint users that interferes with removing the cover on the meter box is a violation of NEC 250.94 (3). The joint user who created the violation must correct the situation.

**4. PCM Location.**

- (a) **Properly supported.** The PCM must be located so that a completed wall will support the back of the meter enclosure.



- (b) **Acceptable location.** The PCM location must be selected and marked with care so that it will not interfere with other tradespersons in the performance of their work. Also, the PCM must not conflict with windows, doors, ledges, dormers, feature details, patios, etc.
- (c) **Moving a PCM.** In the event that it is necessary to move a PCM after the service has been installed, the customer's contractor must relocate the PCM and a DTE Electric crew must relocate the service conductors. Since moving the PCM will require de-energizing the service lateral, the work of the customer's contractor and the DTE Electric crew must be coordinated.
- (d) **Relocation charges.** The customer will be billed for any work done by DTE Electric to relocate or de-energize the service lateral. In some cases, it may be easier and less expensive to install another PCM at the new location and have the service rerouted to it. The old PCM can then be removed and reused at another job site.

## 5. PCM Installation.

- (a) **By Contractor.** The customer's contractor installs the PCM. DTE Electric crews will not install or make any corrections to an improperly installed PCM. The installation must be done in a workmanlike manner so that the PCM is solid and plumb.
- (b) **Compatible with Building.** The PCM must be designed so that it will not have to be moved or modified in any way to complete construction of the wall behind it. The customer must be certain that tradespersons working on the building will not have problems. The various types of wall construction must be taken into consideration.

## 6. Materials.

All support parts for the manufacture of a PCM must be made of solid channel steel (no uni-strut members) and have surface protection that will ensure a long life, particularly those portions in direct contact with the earth where the most severe corrosion can be expected. The thickness of the metal must be such that adequate support and resistance to corrosion will be assured.

## 7. Mounting of Other Equipment.

DTE Electric Planning must accept any equipment that is to be fastened to the PCM assembly temporarily or permanently. Equipment other than DTE Electric devices will not be mounted on the meter enclosure nor depend upon the meter enclosure for support. In particular, any power outlet cabinet intended for use during construction cannot be supported by only a nipple or raceway.

**8. Temporary Construction Service.**

A temporary service power outlet cabinet can be mounted on the PCM assembly providing that it does not depend on the meter enclosure for support. *The person or company installing such temporary service must obtain permission from DTE Electric to break the meter enclosure seal and make connections. If the electric account is closed or the meter is in the disconnect position, application must be made to DTE Electric to install or turn on the electric meter.* The temporary service must be installed in accordance with applicable ordinances and regulations of the governmental inspection authority having jurisdiction and the *National Electrical Code*.

**9. Grade.**

Before calling for service installation, grade on the building site must be established to within 4 inches of final grade. The service route must be clear of building materials, debris, and other obstructions.

**10. Inspected by DTE Electric Planning.**

The following manufactured or fabricated PCM assemblies have been examined by DTE Electric Planning and are acceptable to DTE Electric as submitted. The purpose of this inspection is to protect DTE Electric's interests. There is no intention on the part of DTE Electric to assume any purchaser's responsibility for the decision to use a particular PCM or to police the quality of the delivered unit. The person buying the PCM must examine the assembly to be sure that the manufacture has followed the material and dimension specifications contained in this section. Any party that decides to construct their own PCM assembly should submit a drawing to DTE Electric at [eng\\_standards@dteenergy.com](mailto:eng_standards@dteenergy.com) for approval before installation to avoid a rejection of the installation.

**11. Acceptable Preconstruction Meter Mounts.**

DTE Electric Planner will approve the installation of PCM based on typical installation specifications (see 3-12-4). If builder needs to purchase a PCM, the following preconstruction meter mounts have been accepted for use in the DTE Electric Service Area. Manufacturers desiring to have their equipment listed may contact DTE Electric at [eng\\_standards@dteenergy.com](mailto:eng_standards@dteenergy.com)

(a) *Your Electrical Solutions*  
sales@yourelectricalsolutions.net  
www.yourelectricalsolutions.net  
Toll Free 855.644.2400

(b) *Corby Energy Services*  
6001 Schooner Drive  
Belleville, MI 48111  
734.547.9237  
pcmsales@corbyenergy.com

(c) *B&B Electrical*  
www.bbelec.com  
2804 Orchard Lake Road #203  
Keego Harbor, MI 48320  
248.391.0207

PRECONSTRUCTION METER MOUNT (PCM)  
TYPICAL INSTALLATION

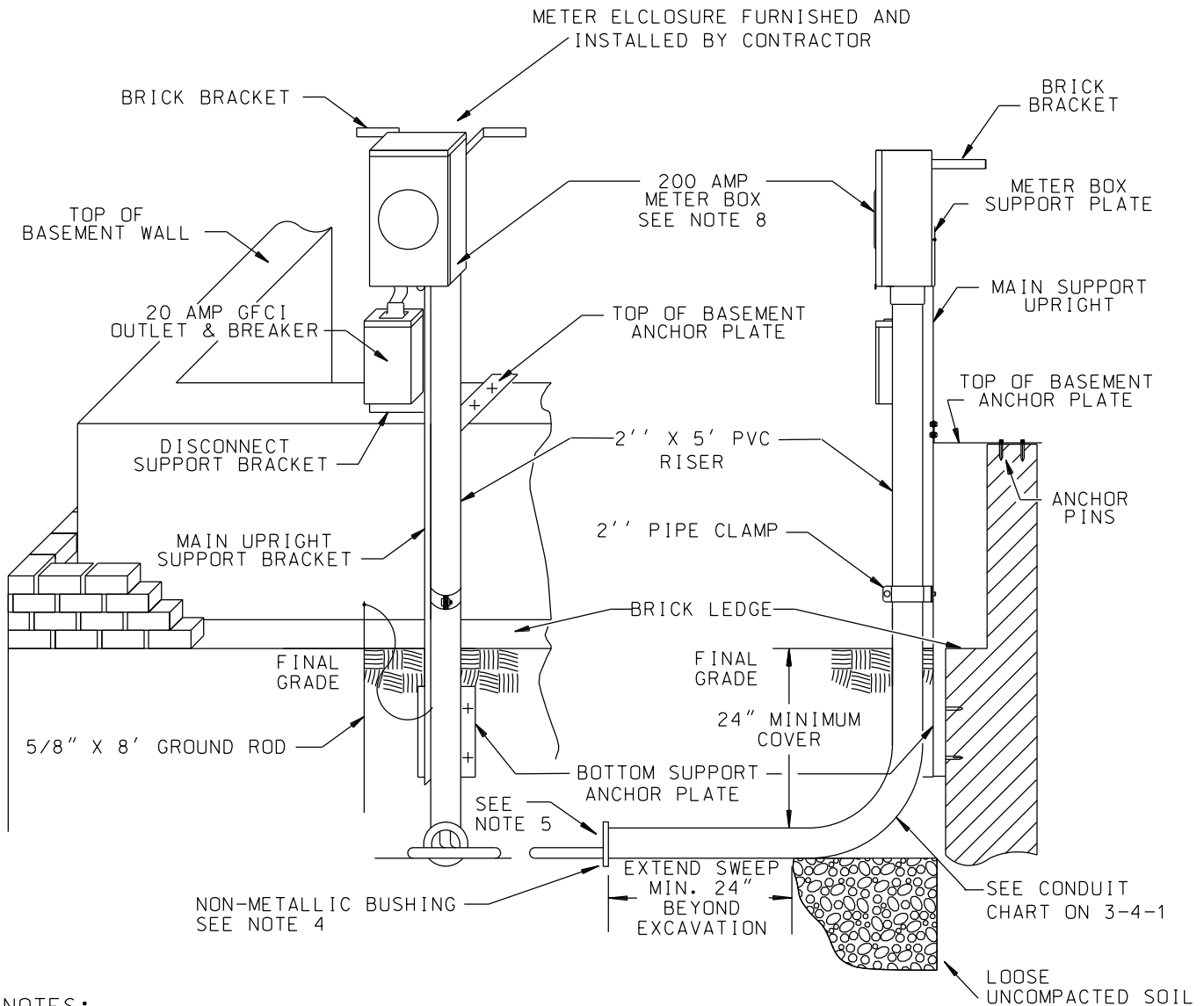

**NOTES:**

1. SEE OTHER PAGES IN THIS SECTION ON UNDERGROUND SERVICE INSTALLATION.
2. MUST COMPLY WITH THE NATIONAL ELECTRICAL CODE AND LOCAL RULES.
3. METER MOUNT CONSTRUCTION AND FASTENING ABOVE AND/OR BELOW GRADE MUST PROVIDE FIRM SUPPORT BEFORE, DURING AND AFTER CONSTRUCTION.
4. USE PLASTIC BUSHING OR INSULATED THROAT BUSHING. BOND PER N.E.C. ARTICLE 250. PVC CONDUIT WITH REAMED AND ROUNDED EDGES DOES NOT REQUIRE BOTTOM BUSHING.
5. BUILDER/ELECTRICIAN MUST MARK THE "BLIND SIDE" OF THE SWEEP.
6. FINAL GRADE MUST BE WITHIN 4" OF THE 24" MINIMUM COVER.
7. USE 2" FOR 3/0 DTE SERVICE (CONSULT PLANNER) RIGID GALVANIZED STEEL CONDUIT INTERMEDIATE METAL CONDUIT (IMC) NEMA TC-2 SCHEDULE 40 PVC.
- ➔ 8. ANY BOND BETWEEN THE METER ENCLOSURE AND JOINT USERS THAT INTERFERES WITH REMOVING THE COVER ON THE METER BOX IS A VIOLATION OF NEC 250.94 (3). THE JOINT USER WHO CREATED THE VIOLATION MUST CORRECT THE SITUATION.

DTE ELECTRIC COMPANY ASSUMES NO RESPONSIBILITY FOR INJURY OR DAMAGE ARISING FROM THE USE OF THIS SPECIFICATION DIAGRAM.

1-9-236

CATV POWER SUPPLY INSTALLATION

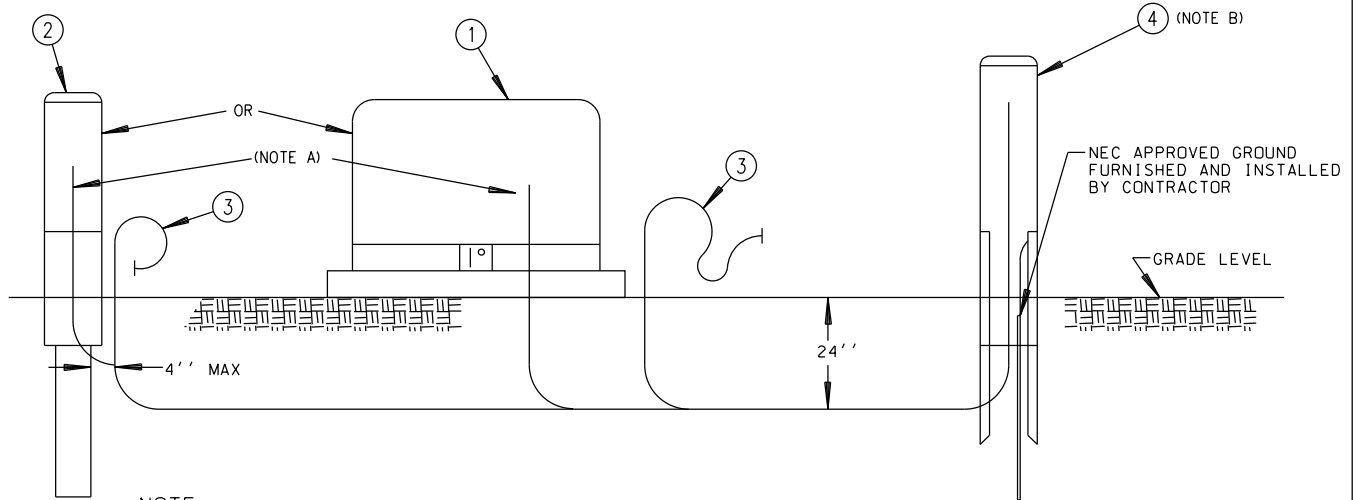

NOTE:

SERVICE CONNECTIONS WILL BE MADE TO TRANSFORMER ONLY WHEN NO PEDESTAL EXISTS

LEGEND:

- 1. DTE ELECTRIC PADMOUNT TRANSFORMER.
- 2. DTE ELECTRIC SECONDARY PEDESTAL. (NOT AVAILABLE FOR FRONT LOT U.R.D.)
- 3. CUSTOMER UNDERGROUND CABLE.
- 4. CATV POWER SUPPLY.

NOTES:

A. SERVICE CABLE

SPECIFICATIONS:

ALUMINUM SINGLE CONDUCTOR TYPE U.S.E. AND CROSS LINKED POLYETHYLENE RHH-RHW.

RESPONSIBILITIES:

CONTRACTOR WILL FURNISH AND INSTALL CABLE UP TO BUT NOT IN OR UNDER TRANSFORMER OR PEDESTAL. DTE ELECTRIC WILL INSTALL AND TERMINATE SERVICE IN TRANSFORMER OR PEDESTAL.

METHOD OF INSTALLATION:

CONTRACTOR WILL CONTACT MISS DIG WHEN WORKING IN PROXIMITY OF DTE ELECTRIC DISTRIBUTION CABLES. HAND DIG CLOSE TO TRANSFORMER, PEDESTAL, OR DISTRIBUTION CABLES. IDENTIFY IF STRIPPING 4" OF INSULATION AT END. ALLOW SUFFICIENT CABLE FOR CONNECTION BY DTE ELECTRIC: 8' AT TRANSFORMER, 4' AT PEDESTAL. SEAL CABLE END AGAINST MOISTURE.

DTE ELECTRIC DETAIL FOR INSTALLATION AND TERMINATION:

TRANSFORMER: SIMILAR TO DETAIL 23227E  
 PEDESTAL: SIMILAR TO DETAIL 23227F

B. CLEARANCES

CATV POWER SUPPLY IS NOT TO BE INSTALLED DIRECTLY OVER DTE ELECTRIC DISTRIBUTION CABLES OR DIRECTLY IN FRONT OF TRANSFORMER DOOR, NOR WITHIN 2' OF ANY EXISTING DTE ELECTRIC FACILITY. IF INSTALLED AT SAME TIME AS DTE ELECTRIC FACILITIES REFER TO PAGE 1-43-72 IN THE UNDERGROUND LINE CONSTRUCTION STANDARDS MANUAL.

DTE ELECTRIC COMPANY ASSUMES NO RESPONSIBILITY FOR INJURY OR DAMAGE ARISING FROM THE USE OF THIS SPECIFICATION DIAGRAM.

**MOBILE HOME SERVICE****1. General.**

The mobile home park owner is responsible for the selection, purchase, installation, and maintenance of the mobile home pedestal. All installations must meet the following conditions to be installed in the DTE Electric service area:

- (a) Installation safety.
- (b) Sufficient load capability.
- (c) Reasonable life expectancy.
- (d) Ease of maintenance.

The electrical contractor responsible for the pedestal installation must review the plans with the DTE Electric Planner *before* beginning construction. The contractor must also comply with the requirements of the municipal inspection authority. DTE Electric offers the following specifications as a guide to mobile home pedestal installations.

**2. Load Capability.**

The standard DTE Electric 3/0 AWG aluminum underground service lateral will adequately feed a 200-ampere service. The *National Electrical Code* and the Mobile Home Manufacturers Association Standard for Mobile Home Parks both set a minimum standard of 100 amperes for mobile home service equipment. Accordingly, mobile home pedestals must have the capability of supplying 100 amperes, and should be constructed so that the main disconnect can be replaced with one of up to 200 amperes capacity without modification to the pedestal. A number of manufacturers offer units with plug-in interchangeable devices to fit a wide variety of loads.

**3. Pedestals and Disconnect Cabinets.**

- (a) **Accepted by DTE Electric Planner.** DTE Electric Planner must accept manufactured or fabricated pedestal assemblies (See page 3-14-19 for acceptable units) *before* installation in the DTE Electric service area.
- (b) **Specifications.** Distributors, representatives or fabricators are required to supply specifications and make a unit available for inspection by OH & UG Construction Standards Group.
- (c) **UL Listed.** Pedestal mains or power outlet cabinets must have UL labels and be listed as suitable for use as service equipment. They must comply with the load requirements in paragraph 2 above and have a weatherproof rating (NEMA 3R).
- (d) **Interrupting Rating.** The short circuit current interrupting rating for the overcurrent device(s) must be a minimum of 10,000 amperes to equal the expected maximum available fault current.

#### 4. Meter Enclosures.

DTE Electric allows the 1  $\Phi$  CL 200 meter enclosure for mounting on the pedestal. Line conductors may enter and load conductors may leave the meter enclosure through the back, providing that the requirements in paragraph 5 are met. The pedestal must be constructed so that an acceptable meter enclosure can be added for interruptible space conditioning or water heating.

- Note: Any bond between the meter enclosure and joint users that interferes with removing the cover on the meter box is a violation of NEC 250.94 (3). The joint user who created the violation must correct the situation.

#### 5. Pedestal Wiring.

- (a) **Conductor Routing.** Conductors must be arranged so that their turning radius will comply with NEC Table 312.6(B) and with good wiring practice. Conductors must be aligned with terminals so that pressure is not exerted.
- (b) **Service Conduit.** Two-inch galvanized rigid steel or Schedule 40 PVC conduit must be provided for the DTE Electric underground service lateral. The edge of the terminal adapter must be covered with a nonmetallic bushing. *Troughs are not permitted.*
- (c) **Bonding.** Close or chase nipples between components must be 1-1/2 inch minimum size. Metallic components must be bonded to one another using appropriate bonding bushings or bonding locknuts.
- (d) **Supply Cord.** A permanent 4-wire feeder is recommended for connecting the mobile home main panel to the pedestal main disconnect. Alternately, a power outlet cabinet and up to three plug-in cables may be used.
- (e) **Conductor Size.** Load conductors between the meter enclosure and the pedestal main disconnect will be 3/0 AWG minimum size.

#### 6. Pedestal Location.

The meter enclosure and service disconnect must *not* be mounted on the mobile home; however, the pedestal should be located within 3 feet as shown on page 3-14-20. The pedestal should face away from the side of the mobile home so that a clear space is provided for access to the meter and service equipment. The preferred orientation is with the meter facing the street. *Pedestal must be plumb.*

#### 7. Mechanical Assembly.

- (a) **Component Mounting.** Pedestal components must be securely fastened using appropriate washers where necessary for solid mounting.
- (b) **Support Posts.** Support posts must be hot dip galvanized steel. Other means of corrosion protection must be accepted by OH & UG Construction Standards. *Wood is not permitted.*

- (c) **Mounting Bolts.** Meter enclosure mounting bolts must be long enough so that an extension can be added for interruptible space conditioning or water heating. An extra nut should be provided on each bolt as shown on page 3-14-20.
- (d) **Approved Posts.** The following support posts will provide a reasonably long life in most soil conditions. Other posts may be used, but must be accepted by OH & UG Construction Standards Group.
  - (1) **Rigid steel conduit (2 in)**  
Hot dip galvanized  
(Intermediate metal conduit or fence post is **not** acceptable.)
  - (2) **Square seamless post (1-3/4 in)** 12-gage min.  
Hot dip galvanized  
(*Unistrut Corp.* TELESPAR® Part No. 16F12 or equivalent)

**8. Grounding.**

A ground rod shall be driven at each pedestal location. Material and installation must comply with NEC Article 250.

**9. Mounting of Other Equipment.**

Other utility equipment that is mounted on the pedestal must not interfere with the use of the electrical equipment. (See page 3-14-21) Fastening hardware must not present a hazard to any conductors.

**10. Acceptable Pedestals.**

DTE Electric Planner will approve the installation of pedestals based on typical installation specifications (see 3-4-6 & 3-4-6.1, and 3-14-20 to 3-14-25). If builder needs to purchase a pedestal, the following pedestals have been accepted for use in the DTE Electric service area. Manufacturers desiring to have their equipment listed may contact DTE Electric at [eng\\_standards@dteenergy.com](mailto:eng_standards@dteenergy.com)

- |                                                                                                                      |                                                                                                                   |                                                                                                                          |
|----------------------------------------------------------------------------------------------------------------------|-------------------------------------------------------------------------------------------------------------------|--------------------------------------------------------------------------------------------------------------------------|
| <p>(a) <i>Adnic Products Co.</i><br/>G6261 N. Saginaw Rd.<br/>Mt. Morris, MI 48458<br/>810.785.2851</p>              | <p>(c) <i>Midwest Electric</i><br/>P.O. Box 910<br/>Hwy. 22 North<br/>Mankato, MN 56002-0910<br/>506.345.2505</p> | <p>(e) <i>Rollman Electric Co.</i><br/>3351 Consear<br/>Lambertville, MI 48144<br/>734.856.1900</p>                      |
| <p>(b) <i>B &amp; B Electrical Manufacturing</i><br/>2737 Browning Dr.<br/>Lake Orion, MI 48360<br/>248.391.3800</p> | <p>(d) <i>Power Plus Industries, Inc.</i><br/>16537 Fairway<br/>Livonia, MI 48154<br/>734.464.6273</p>            | <p>(f) <i>Nordic Fiberglass, Inc.</i><br/>21415 U.S. Hwy 75 NW<br/>P.O. Box 27<br/>Warren, MN 56762<br/>218.745.5095</p> |

MOBILE HOME PEDESTAL SERVED UNDERGROUND

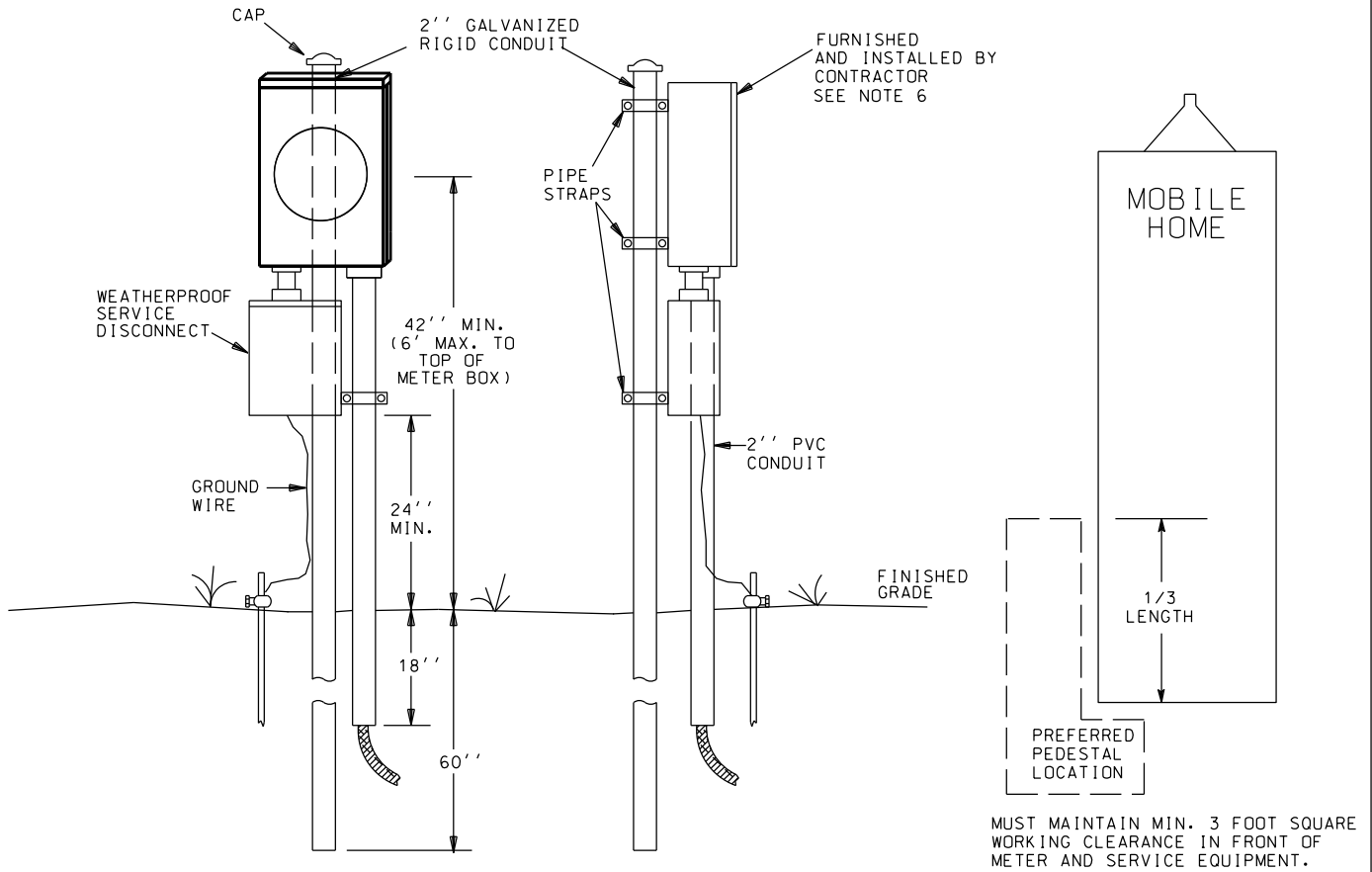

INTERRUPTIBLE SPACE CONDITIONING

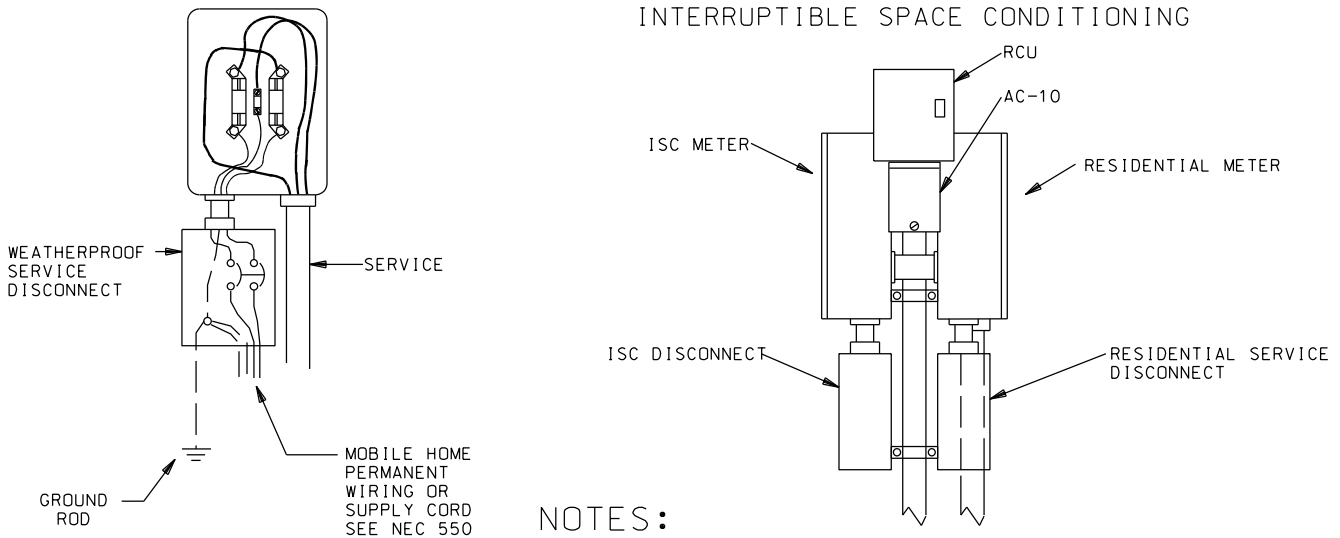

NOTES:

1. SEE DETAILED SPECIFICATIONS ON PAGE 3-14-17.
2. MOBILE HOME SERVICE AND FEEDER (PERMANENT WIRING OR SUPPLY CORD) MUST COMPLY WITH NEC ARTICLE 550.
3. GROUNDING MUST COMPLY WITH NEC ARTICLE 250.
4. SERVICE EQUIPMENT SHALL BE RATED AT NOT LESS THAN 100 AMPS.
5. FOR WATER HEATER INSTALLATION, SEE PAGES 7-27-1 THROUGH 7-27-4.
- ➔ 6. ANY BOND BETWEEN THE METER ENCLOSURE AND JOINT USERS THAT INTERFERES WITH REMOVING THE COVER ON THE METER BOX IS A VIOLATION OF NEC 250.94 (3). THE JOINT USER WHO CREATED THE VIOLATION MUST CORRECT THE SITUATION.

DTE ELECTRIC COMPANY ASSUMES NO RESPONSIBILITY FOR INJURY OR DAMAGE ARISING FROM THE USE OF THIS SPECIFICATION DIAGRAM.



## JOINT USE MOBILE HOME PEDESTAL INSTALLATION

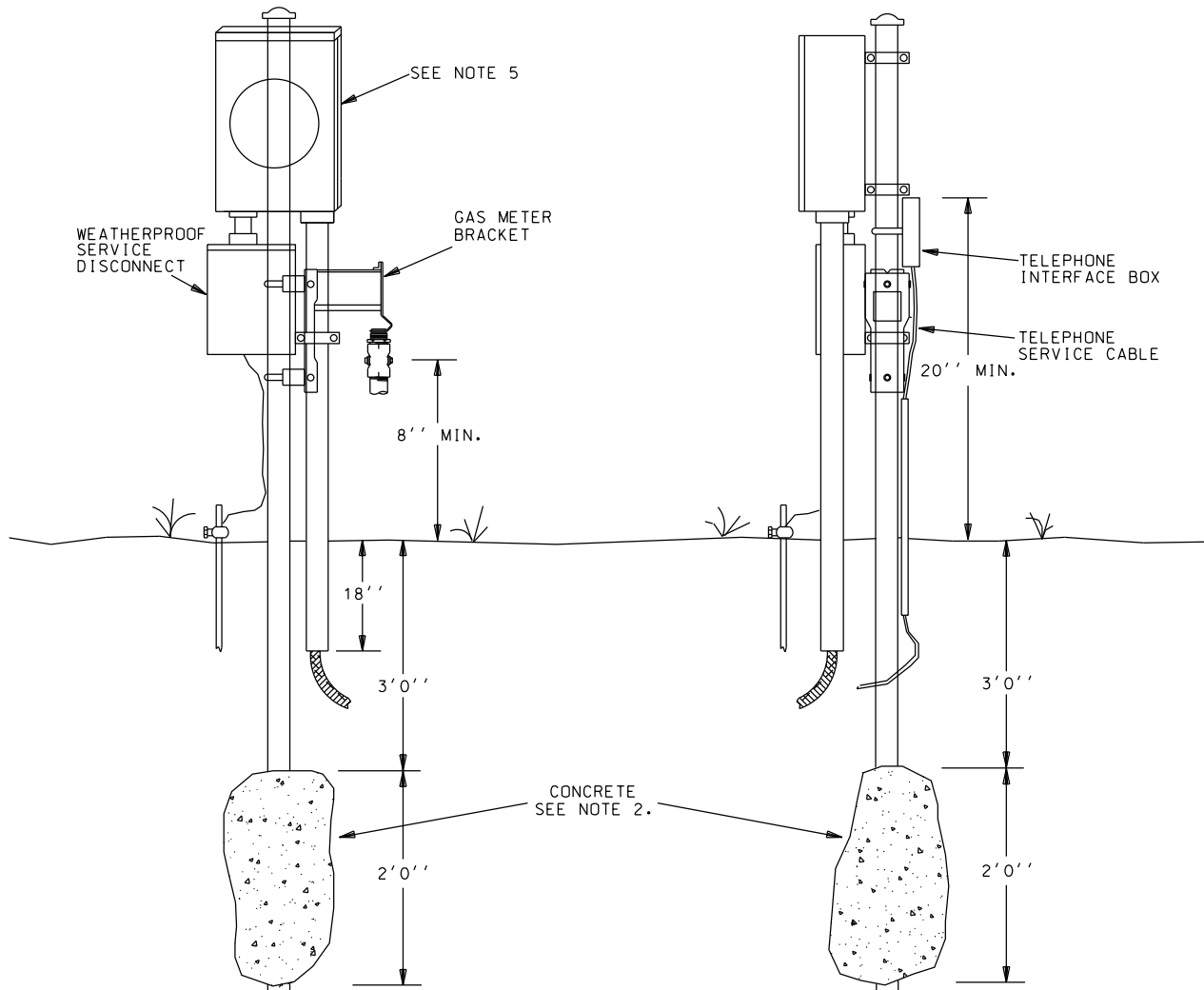

## NOTES:

1. THIS POST INSTALLATION METHOD IS TO BE USED ONLY WHEN THE MOBILE HOME PARK IS JOINT USE.
2. GAS COMPANY PERSONNEL WILL INSPECT AND BE RESPONSIBLE FOR THE PROPER TREATMENT OF THE CONCRETE. WARNING - IF CONCRETE IS ABOVE THE LEVEL SHOWN, FROST HEAVE IS LIKELY TO OCCUR.
3. SEE PAGES 3-14-17 THRU 20 FOR ELECTRICAL PEDESTAL INSTRUCTIONS AND SPECIFICATIONS.
4. REFER TO THE GAS COMPANY FOR GAS METER INSTALLATION INSTRUCTIONS.
- ➡ 5. ANY BOND BETWEEN THE METER ENCLOSURE AND JOINT USERS THAT INTERFERES WITH REMOVING THE COVER ON THE METER BOX IS A VIOLATION OF NEC 250.94 (3). THE JOINT USER WHO CREATED THE VIOLATION MUST CORRECT THE SITUATION.

DTE ELECTRIC COMPANY ASSUMES NO RESPONSIBILITY FOR INJURY OR DAMAGE ARISING FROM THE USE OF THIS SPECIFICATION DIAGRAM.

POST MOUNTED UNDERGROUND SERVICE, 100 TO 200 AMP  
 SINGLE PHASE OR THREE PHASE, USED FOR MOBILE HOME COMMUNITY  
 OR ANY LOCATION THAT REQUIRES A REMOTE METER

SEE NOTE 2

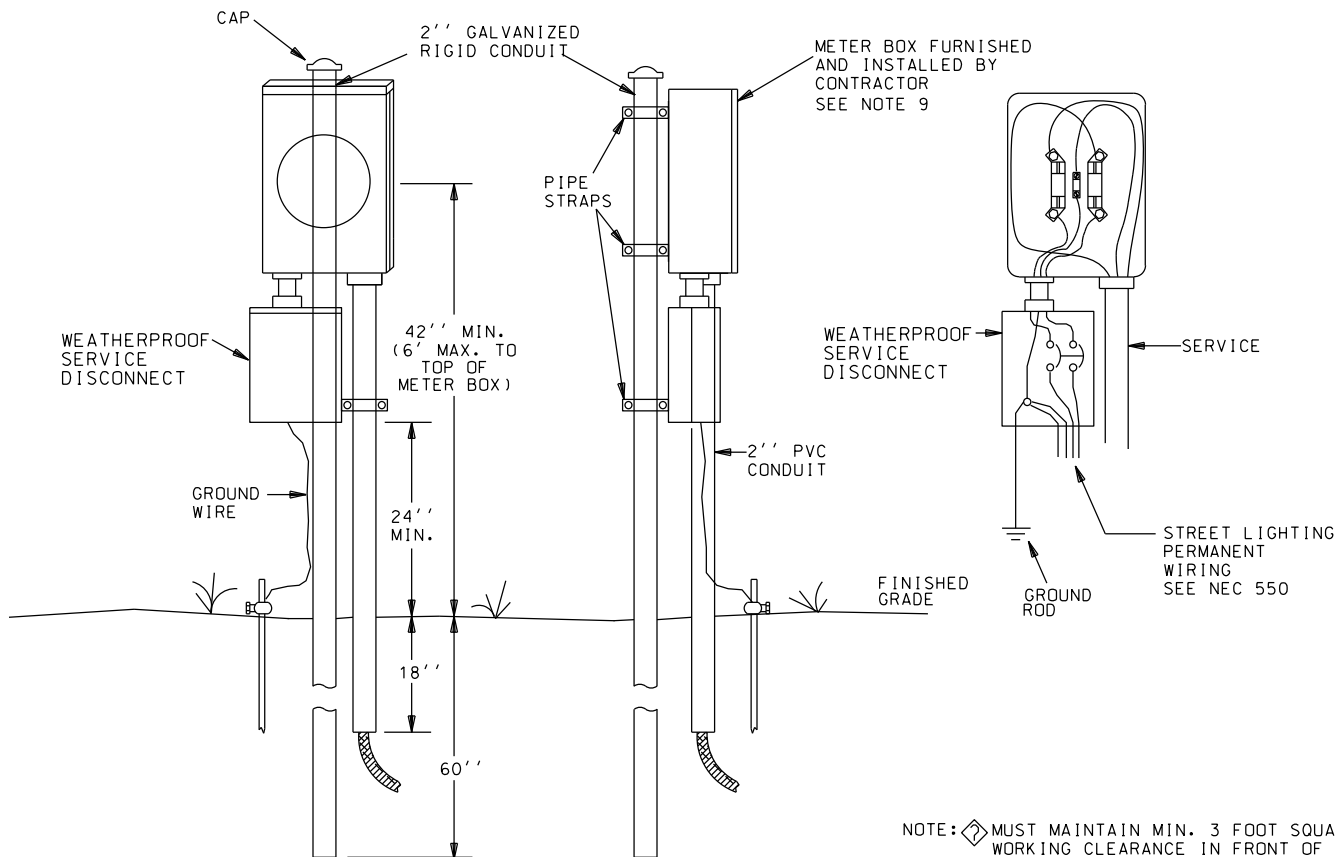

NOTES:

1. ALL POST MOUNTED SERVICE EQUIPMENT, OTHER THAN THE METER BOX IS OWNED AND MAINTAINED BY THE CUSTOMER.
2. METER BOX MAY BE:  
 CL 200 FOR 100 TO 200 AMP SINGLE PHASE  
 CL 200 FOR 100 TO 200 AMP THREE PHASE

REFERENCE PAGE  
 5-3-5  
 5-3-18 & 19

42" MINIMUM HEIGHT TO CENTER OF METER FACE FROM GRADE AND  
 6" MAXIMUM TO TOP OF METER BOX.

3. USE ONLY 2" RIGID PIPE POST WITH CAP. WOOD POSTS ARE NOT ALLOWED. THE POST MUST BE INSTALLED PLUMB AND REMAIN PLUMB AT ALL TIMES.
4. SERVICE DISCONNECT MUST BE RAINTIGHT. THE DISCONNECT IS SIZED, FURNISHED AND INSTALLED BY CUSTOMER.
5. RIGID AND IMC CONDUIT REQUIRE NONMETALLIC BUSHINGS WITH BONDING PER N.E.C. 250. PVC CONDUIT MUST BE TRIMMED TO REMOVE SHARP EDGES.
6. DTE ELECTRIC INSTALLED UG SERVICES REQUIRE 2" CONDUIT FOR 3/0 SINGLE PHASE SERVICE AND 3" CONDUIT FOR THREE PHASE 3/0 SERVICES.
7. A GROUND ROD MUST BE INSTALLED IN COMPLIANCE WITH N.E.C. 250.
8. ADDRESS MUST BE PERMANENTLY MARKED ON METER ENCLOSURE. USE PERMANENT LETTERS OR STICKERS.
- ➡ 9. ANY BOND BETWEEN THE METER ENCLOSURE AND JOINT USERS THAT INTERFERES WITH REMOVING THE COVER ON THE METER BOX IS A VIOLATION OF NEC 250.94 (3). THE JOINT USER WHO CREATED THE VIOLATION MUST CORRECT THE SITUATION.

DTE ELECTRIC COMPANY ASSUMES NO RESPONSIBILITY FOR INJURY OR DAMAGE ARISING FROM THE USE OF THIS SPECIFICATION DIAGRAM.

PEDESTAL MOUNTED UNDERGROUND SERVICE  
SECONDARY VOLTAGE OVER 200 AMPS

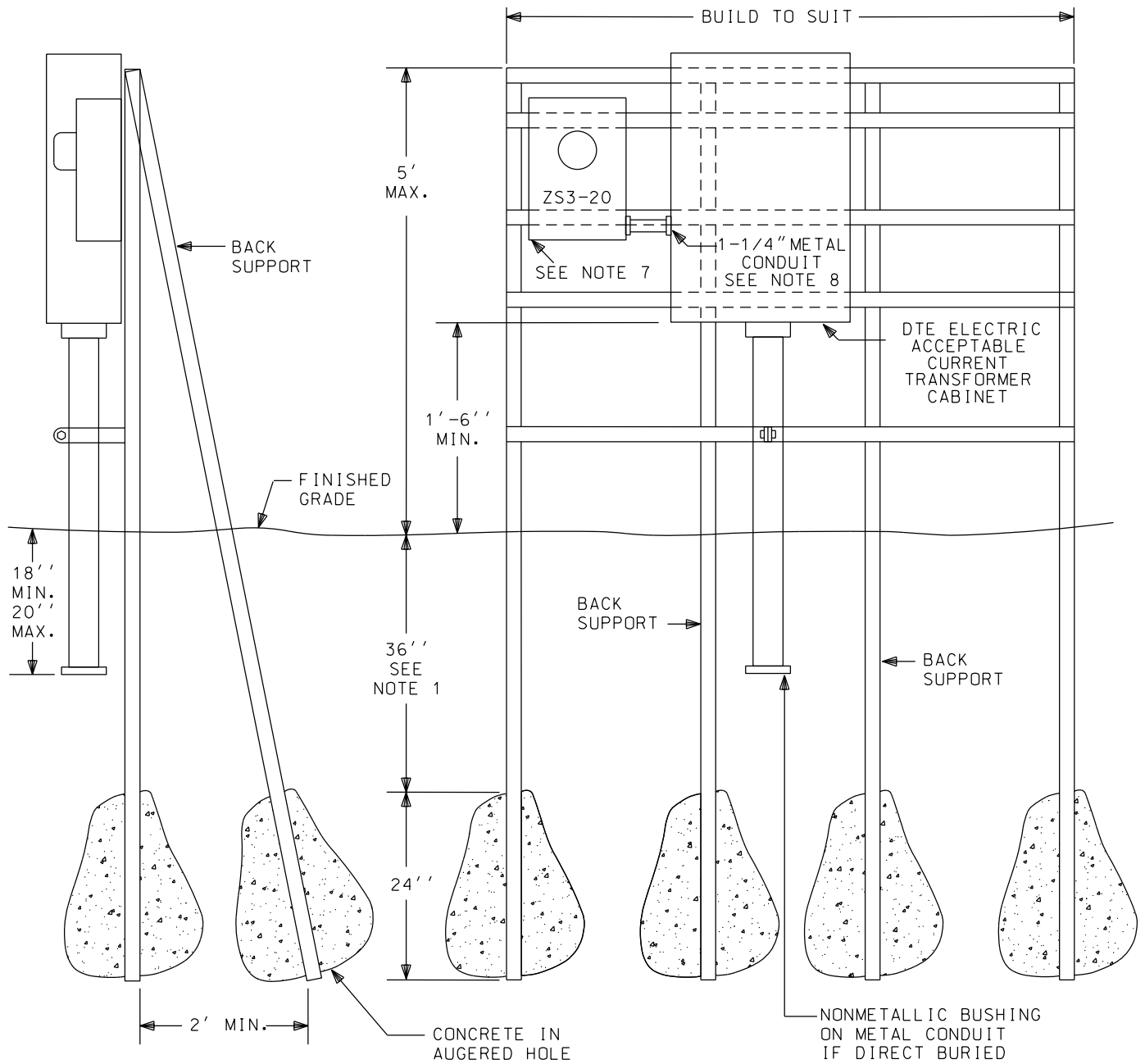

NOTES:

1. AREA 3 FEET BELOW GRADE MUST BE KEPT FREE OF CONCRETE. (THIS WILL MINIMIZE FROST HEAVE)
2. SUPPORTS MUST BE MINIMUM 12 GAUGE AND HOT DIPPED GALVANIZED.
3. THE CUSTOMER IS RESPONSIBLE FOR OWNERSHIP AND MAINTAINANCE OF THE PEDESTAL.
4. THE CONTRACTOR WILL FURNISH AND INSTALL A SEPARATE GROUNDING ELECTRODE PER NEC 250.
5. UNISTRUT OR EQUIVALENT METAL FRAMING AND FITTINGS.
6. ANY DEVIATIONS FROM THE SPECIFICATIONS ABOVE MUST BE ACCEPTED BY DESIGN PRACTICES PRIOR TO INSTALLATION.
7. ANY BOND BETWEEN THE METER ENCLOSURE AND JOINT USERS THAT INTERFERES WITH REMOVING THE COVER ON THE METER BOX IS A VIOLATION OF NEC 250.94 (3). THE JOINT USER WHO CREATED THE VIOLATION MUST CORRECT THE SITUATION.
8. SEE 5-3-19.1 FOR CONDUIT ENTRANCES.

DTE ELECTRIC COMPANY ASSUMES NO RESPONSIBILITY FOR INJURY OR DAMAGE ARISING FROM THE USE OF THIS SPECIFICATION DIAGRAM.

TELEPHONE COMPANY POWER PEDESTAL**1. General.**

The Telephone Company is responsible for the selection, purchase, installation, and maintenance of the power pedestal. All installations must meet the following conditions to be installed in the DTE Electric service area:

- (a) Installation safety.
- (b) Sufficient load capability.
- (c) Reasonable life expectancy.
- (d) Ease of maintenance.

The electrical contractor responsible for the pedestal installation must review the plans with the DTE Electric Planner *before* beginning construction. The contractor must also comply with the requirements of the municipal inspection authority. DTE Electric offers the following specifications as a guide for power pedestal installations:

**2. Load Capability.**

The pedestal must accept the standard DTE Electric 3/0 AWG aluminum underground service lateral and be capable of supplying 200 amperes.

**3. Pedestals and Disconnects.**

- (a) **Accepted by OH & UG Construction Standards.** DTE Electric OH & UG Construction Standards must accept manufactured or fabricated pedestal assemblies *before* installation in the DTE Electric service area. (See page 3-14-19 for accepted manufacturers.)
- (b) **Specifications.** Distributors, representatives or fabricators are required to supply specifications and make a unit available for inspection by OH & UG Construction Standards.
- (c) **UL Listed.** Pedestal mains and transfer switch cabinets must have UL labels and be listed as suitable for use as service equipment. They must comply with the load requirements in paragraph 2 above and have a weatherproof rating (NEMA 3R).
- (d) **Interrupting Rating.** The short circuit current interrupting rating for the overcurrent device(s) must be a minimum of 10,000 amperes to equal the expected maximum available fault current.

**4. Meter Enclosures.**

DTE Electric allows the 1  $\Phi$  CL 200 meter enclosure for mounting on the pedestal. Line conductors may enter and load conductors may leave the meter enclosure through the back, providing the requirements in paragraph 5 are met.

- Note: Any bond between the meter enclosure and joint users that interferes with removing the cover on the meter box is a violation of NEC 250.94 (3). The joint user who created the violation must correct the situation.

## 5. Pedestal Wiring.

- (a) **Conductor Routing.** Conductors must be arranged so that their turning radius will comply with NEC Article 312 and with good wiring practice. Conductors must be aligned with terminals so that pressure is not exerted.
- (b) **Service Conduit.** Two-inch galvanized rigid steel or Schedule 40 PVC conduit must be provided for the DTE Electric underground service lateral. The edge of the terminal adapter must be covered with a nonmetallic bushing. *Troughs are not permitted.*
- (c) **Bonding.** Close or chase nipples between components must be 1-1/2 inch minimum size. Metallic components must be bonded to one another using appropriate bonding bushings or bonding locknuts.

## 6. Mechanical Assembly.

- (a) **Component Mounting.** Pedestal components shall be securely fastened using appropriate washers where necessary for solid mounting.
- (b) **Support Posts.** Support posts must be hot dip galvanized steel. Other means of corrosion protection must be accepted by DTE Electric Planning. *Wood is not permitted.*
- (c) **Hardware.** Fasteners used for assembly of components must have adequate mechanical strength to assure dependable service.
- (d) **Approved Posts.** The following support posts will provide a reasonably long life in most soil conditions. Other posts may be used, but must be accepted by DTE Electric Planning.
  - (1) **Rigid steel conduit (2 in)**  
Hot dip galvanized  
(Intermediate metal conduit or fence post is **not** acceptable.)
  - (2) **Square seamless post (1-3/4 in)** 12-gage min.  
Hot dip galvanized  
(*Unistrut Corp. TELESPAR® Part No. 16F12 or equivalent*)

## 7. Grounding.

A ground rod shall be driven at each pedestal location. Material and installation must comply with NEC Article 250.

## 8. Mounting of Other Equipment.

Surge arresters will be connected on the load side of the main overcurrent device and will not be mounted in the meter enclosure.

**9. Transfer Switch.**

If arrangements are made to supply auxiliary power, either on-site or portable, safety precautions are necessary for public and utility personnel protection:

- (a) Double-throw transfer switch must break DTE Electric supply before closing to standby power source. Switch need not be fusible but it must be weatherproof.
- (b) Switch size will be determined by ampere capacity of largest conductor to be connected.
- (c) Switch may control entire load or a portion thereof. Preferably, switch will be on load side of main.
- (d) Switch will be visibly open to DTE Electric supply, although a dead front may have to be removed for this inspection.
- (e) Metering must not be affected by arrangements for supplying auxiliary power. Metered and unmetered conductors will not be intermingled.

TELEPHONE COMPANY POWER PEDESTAL  
FOR PAD MOUNTED CARRIER SYSTEM

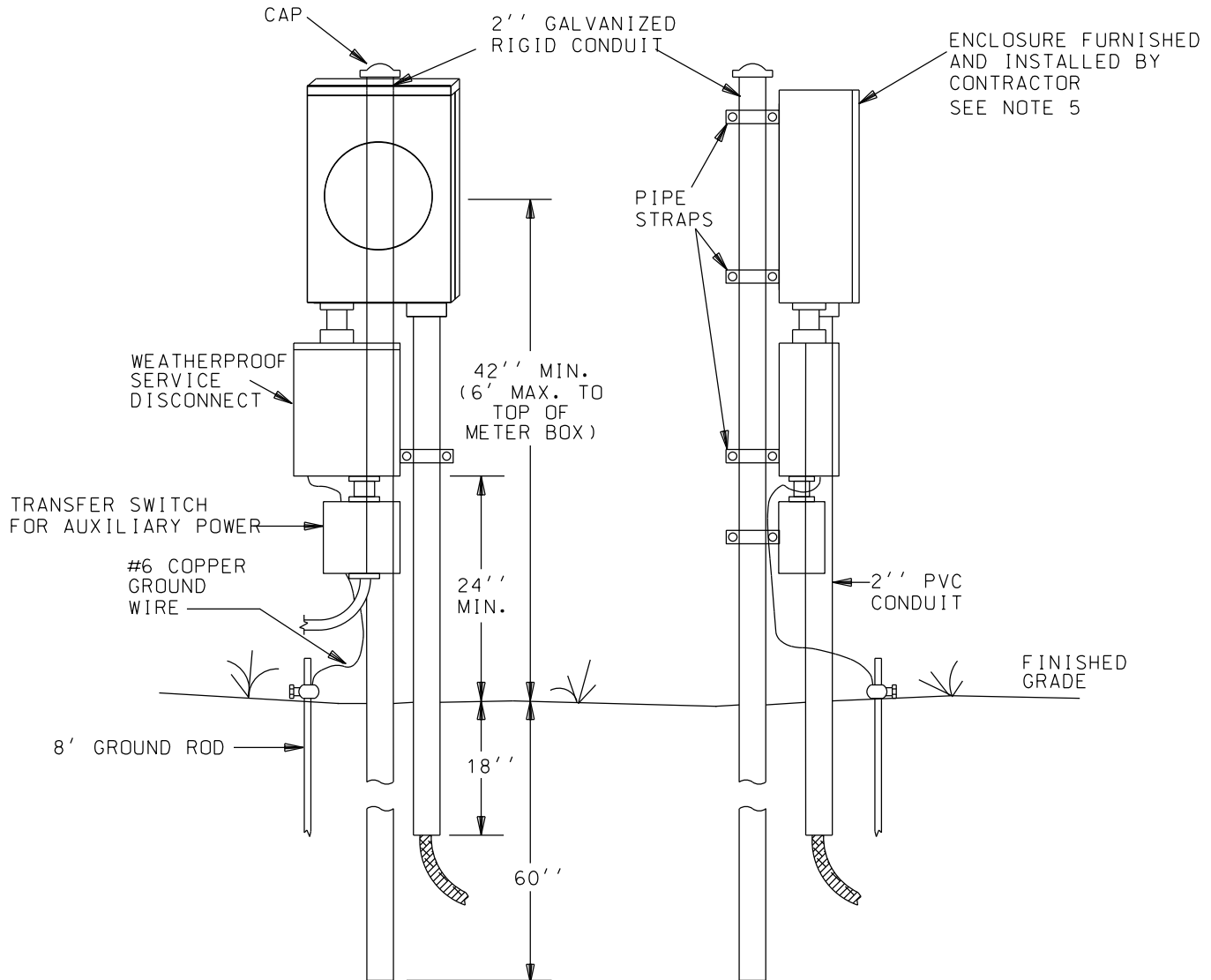

NOTES:

1. DTE APPROVED METER ENCLOSURE FURNISHED AND INSTALLED BY TELEPHONE COMPANY CONTRACTOR.
2. SERVICE ENTRANCE MAIN SWITCH FURNISHED AND INSTALLED BY TELEPHONE COMPANY CONTRACTOR.
3. SUPPORT CONDUIT FURNISHED AND INSTALLED BY TELEPHONE COMPANY CONTRACTOR.
4. SEE DETAILED NOTES ON SIM-ESIG PAGE 3-15-1 THROUGH 3-15-3.
- ➡ 5. ANY BOND BETWEEN THE METER ENCLOSURE AND JOINT USERS THAT INTERFERES WITH REMOVING THE COVER ON THE METER BOX IS A VIOLATION OF NEC 250.94 (3). THE JOINT USER WHO CREATED THE VIOLATION MUST CORRECT THE SITUATION.

DTE ELECTRIC COMPANY ASSUMES NO RESPONSIBILITY FOR INJURY OR DAMAGE ARISING FROM THE USE OF THIS SPECIFICATION DIAGRAM.

CELLULAR TOWER SERVICE  
MULTIPLE SERVICES TO  
A SINGLE TOWER

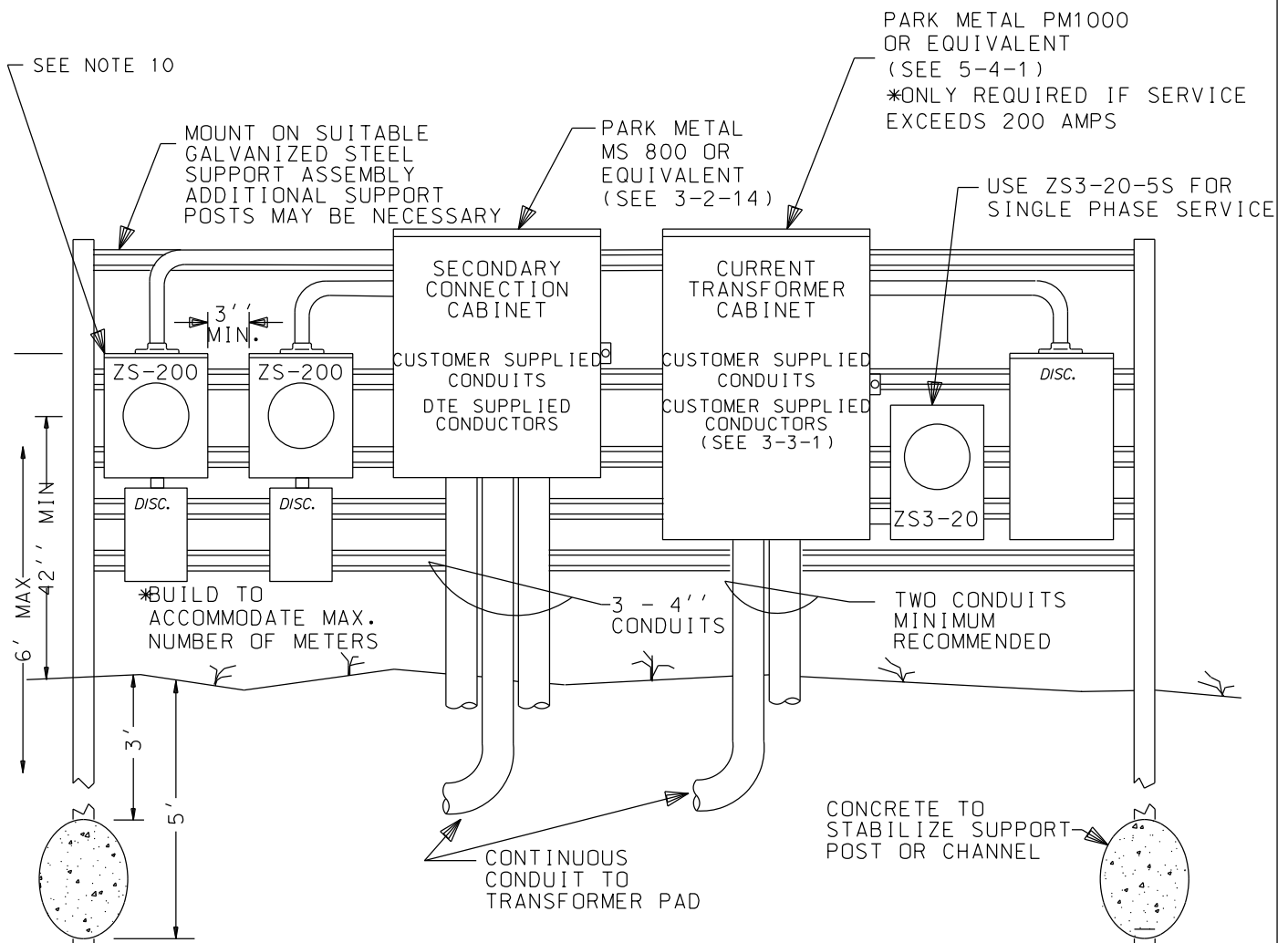

## NOTES:

1. CABINETS AND CONDUITS FURNISHED AND INSTALLED BY CUSTOMER. SERVICE CONDUCTORS TO CONNECTION CABINET FURNISHED AND INSTALLED BY DTE. SERVICE CONDUCTORS TO CT CABINET FURNISHED AND INSTALLED BY CONTRACTOR.
2. EQUIPMENT ASSEMBLY DRAWINGS AND RISER DIAGRAMS MUST BE SUBMITTED TO A DTE ELECTRIC PLANNER FOR ACCEPTANCE PRIOR TO INSTALLATION.
3. CABINETS AND CONDUITS SHOWN SHALL CONTAIN ONLY UNMETERED LINE CONDUCTORS. CABINETS SHALL BE SEALABLE WITH ACCEPTABLE SEALING HASPS. SEE PAGES 5-6-9 AND 5-6-10.
4. TRANSMISSION TOWER SERVICES WILL TYPICALLY UTILIZE A 200 AMP SERVICE WITH CONTINUOUS CONDUIT TO THE SOURCE.
5. SUBSTATION CELLULAR SERVICES WILL TYPICALLY UTILIZE A 200 AMP SERVICE OR BUILT TO THIS SPECIFICATION. NO SERVICES SHALL BE TAKEN OUT OF THE SUBSTATION HOUSE SERVICE.
6. FOR SERVICES EXCEEDING 200A A SINGLE PHASE CT CABINET WILL BE USED. 3 PHASE AVAILABLE WHERE APPLICABLE.
7. ALL CONDUIT AND NIPPLE ENTRIES TO CABINETS AND METER BOXES MUST BE MADE WITH WEATHERPROOF HUBS, CONNECTORS OR LOCKNUTS LISTED FOR THE APPLICATION. NONMETALLIC BUSHINGS REQUIRED.
8. FOR INACCESSIBLE LOCATIONS CONSULT WITH CUSTOMER SERVICE ENGINEERING FOR POSSIBLE ERT METER INSTALLATION.
9. ONLY ONE SERVICE ALLOWED PER LUG. ALL GROUNDING AND BONDING MUST COMPLY WITH NEC 250.
10. ANY BOND BETWEEN THE METER ENCLOSURE AND JOINT USERS THAT INTERFERES WITH REMOVING THE COVER ON THE METER BOX IS A VIOLATION OF NEC 250.94 (3). THE JOINT USER WHO CREATED THE VIOLATION MUST CORRECT THE SITUATION.

DTE ELECTRIC COMPANY ASSUMES NO RESPONSIBILITY FOR INJURY OR DAMAGE ARISING FROM THE USE OF THIS SPECIFICATION DIAGRAM.



CELLULAR TOWER SERVICE  
2X200A MAX SERVICES TO  
A TRANSMISSION TOWER

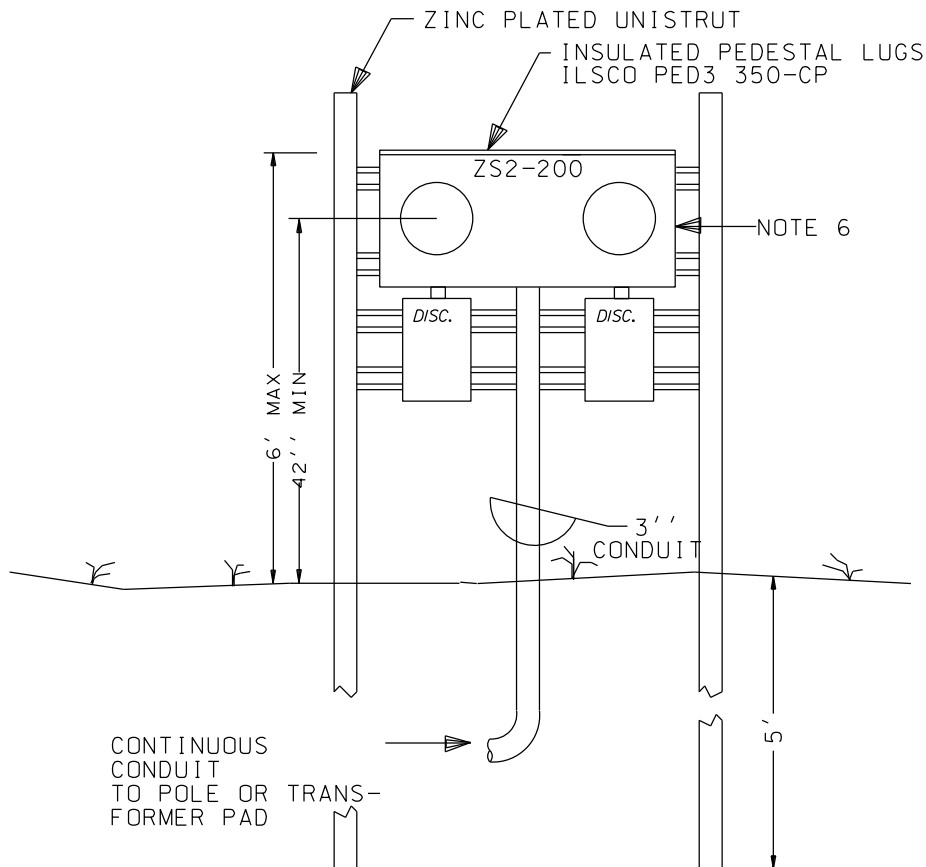

**NOTES:**

1. CONDUIT FURNISHED AND INSTALLED BY CUSTOMER.  
350 KCMIL SERVICE CONDUCTORS FURNISHED AND INSTALLED BY DTE.
2. EQUIPMENT ASSEMBLY DRAWINGS AND RISER DIAGRAMS MUST BE SUBMITTED TO A DTE ELECTRIC PLANNER FOR ACCEPTANCE PRIOR TO INSTALLATION.
3. ALL CONDUIT AND NIPPLE ENTRIES TO METER BOXES MUST BE MADE WITH WEATHERPROOF HUBS, CONNECTORS OR LOCKNUTS LISTED FOR THE APPLICATION. NONMETALLIC BUSHINGS REQUIRED.
4. FOR INACCESSIBLE LOCATIONS CONSULT WITH CUSTOMER SERVICE ENGINEERING FOR POSSIBLE ERT METER INSTALLATION.
5. ONLY ONE SERVICE ALLOWED PER LUG.  
ALL GROUNDING AND BONDING MUST COMPLY WITH NEC 250.
6. ANY BOND BETWEEN THE METER ENCLOSURE AND JOINT USERS THAT INTERFERES WITH REMOVING THE COVER ON THE METER BOX IS A VIOLATION OF NEC 250.94 (3). THE JOINT USER WHO CREATED THE VIOLATION MUST CORRECT THE SITUATION.

DTE ELECTRIC COMPANY ASSUMES NO RESPONSIBILITY FOR INJURY OR DAMAGE ARISING FROM THE USE OF THIS SPECIFICATION DIAGRAM.

HIGH RISE DRY TYPE TRANSFORMERS  
167 AND 300 KVA

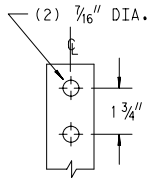

PRIMARY TERMINAL

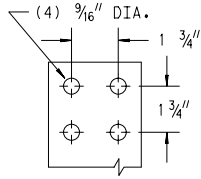

SECONDARY TERMINAL

KVA	PRIMARY	SECONDARY	PHASE	WEIGHT
167	4800 X 13200 V	120/240 V	1	2410 LBS
300	4800 X 13200 V	120/208 V	3	4500 LBS
300	4800 X 13200 V	277/480 V	3	4500 LBS

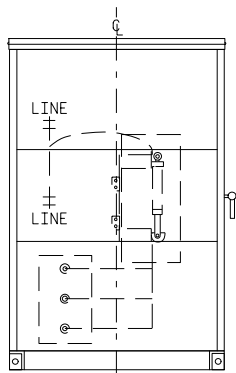

LEFT

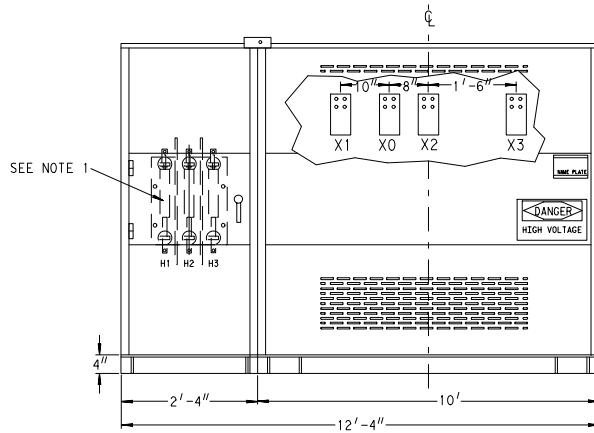

FRONT

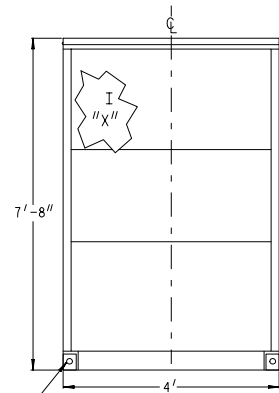

RIGHT

TYPICAL 300 KVA 4.8 X 13.2KV DUAL VOLTAGE

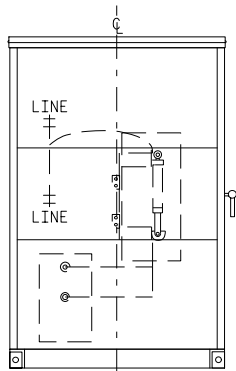

LEFT

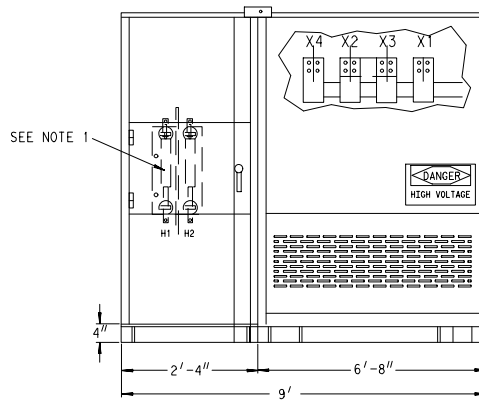

FRONT

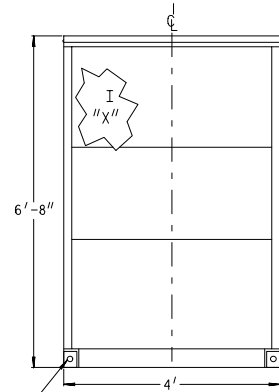

RIGHT

TYPICAL 167 KVA 4.8 X 13.2KV DUAL VOLTAGE

NOTES:

1. PRIMARY FUSE CABINET WITH HINGED DOOR WITH PADLOCKABLE HANDLE. FUSE CABINET CAN BE FITTED TO EITHER RIGHT OR LEFT SIDE OF TRANSFORMER.
2. COMMERCIAL FREIGHT ELEVATOR WEIGHT MUST HAVE CAPACITY OF 5000 LBS. OR MORE TO INSTALL.
3. THE ELEVATOR AND HALLWAY SHALL BE SUFFICIENT TO ACCOMMODATE THE DIMENSIONS (SHOWN ON SIM-ESIG 3-15-8) AND WEIGHT (LISTED ABOVE) OF THE DRY TYPE UNIT.
4. THE TRANSFORMER AND METERING EQUIPMENT SHALL BE LOCATED IN THE SAME ROOM. SEE SIM-ESIG 5-3-9.1.

DTE ELECTRIC COMPANY ASSUMES NO RESPONSIBILITY FOR INJURY OR DAMAGE ARISING FROM THE USE OF THIS SPECIFICATION DIAGRAM.

HIGH RISE TRANSFORMER FOOTPRINT

1-17-278

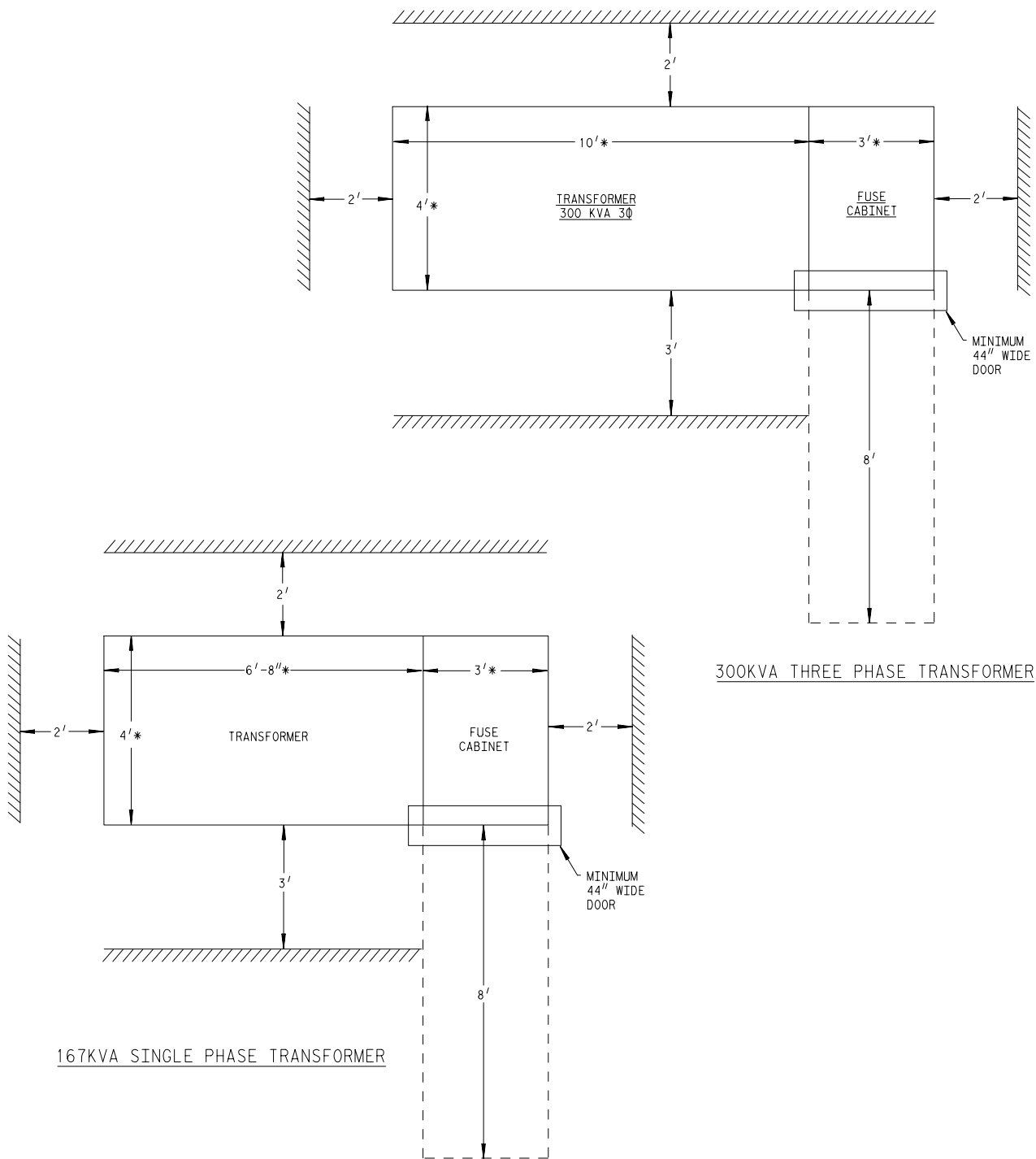

NOTES:

1. THE ELEVATOR AND HALLWAY SHALL BE SUFFICIENT TO ACCOMMODATE THE DIMENSIONS SHOWN ABOVE) AND WEIGHT (LISTED ON SIM-ESIG 3-15-7) OF THE DRY TYPE UNIT.
2. ADDITIONAL CLEARANCES MAY BE REQUIRED FOR METERING.
- \*3. LISTED EQUIPMENT DIMENSIONS ARE TYPICAL AND SUBJECT TO CHANGE.
4. ROOM MUST ALSO BE LARGE ENOUGH TO ACCOMMODATE METERING EQUIPMENT SERVED BY THE TRANSFORMERS.

DTE ELECTRIC COMPANY ASSUMES NO RESPONSIBILITY FOR INJURY OR DAMAGE ARISING FROM THE USE OF THIS SPECIFICATION DIAGRAM.

**Section 3 SIM-ESIG  
Sequence List**

<b>Section 3 SIM-ESIG</b>	<b>Year</b>	<b>Revision Description</b>
03-01-08	Feb-16	No Change
03-01-09	Feb-16	No change
03-01-10	Oct-17	Added NEC meter box note
03-01-11	Oct-17	Added NEC meter box note
03-02-11	Feb-16	No change
03-02-12	Feb-16	No Change
03-02-13	Dec-20	Added customer installation note to note 3
03-02-14	Dec-20	Added customer installation note to note 3
03-02-15	Sep-22	Corrected "meter box" to "service riser"
03-02-16	Nov-18	Added provision for upgrade from CL200 to CL320 (customer contractor note 3)
03-02-17	Feb-23	Added notes 10-12
03-03-01	Apr-17	Updated NEC reference
03-03-02	Oct-20	Added note (k)
03-03-03	Apr-17	Updated NEC table number
03-03-04	Jan-20	Clarified process in 6(c)(3)
03-03-05	Feb-16	No Change
03-03-06	Jul-16	Changed 3/0 4-Wire from 3 in to 2-1/2 in
03-03-07	Feb-16	No Change
03-03-08	Mar-23	Updated reference pages for transformer foundations
03-03-09	Feb-16	No Change
03-04-01	Feb-21	Edited note 2 to remove reference to 350 Al, edited table to remove reference to 3" and 4" conduits.
03-04-02	Feb-16	Obselete
03-04-03	Feb-16	Obselete
03-04-3.1	Oct-17	Added NEC meter box note
03-04-3.2	Jan-19	Removed residential only qualification
03-04-04	Feb-16	Removed reference to 2/0
03-04-05	Jul-21	Maximum cable size and sweep height added
03-04-06	Oct-17	Added NEC meter box note
03-04-6.1	18-Feb	New spec - Fiberglass metered pedestal
03-04-07	Jun-23	Changed note 5 to reflect pedastal required for more than one service
03-04-08	Jun-23	Changed note 5 to reflect pedastal required for more than one service
03-04-09	Jul-21	Maximum cable size and sweep height added
03-04-11	Feb-16	No change
03-05-11	Oct-17	Added NEC meter box note
03-05-12	Oct-17	Added NEC meter box note
03-05-15	Feb-16	No Change
03-05-16	Feb-16	No Change
03-05-17	Feb-16	Changed 2/0 to 3/0
03-05-18	Feb-16	Added new MPSC rule for UG
03-06-01	Jun-23	Added information regarding primary/secondary windows and main reinforcing bars.
03-06-02	Jun-23	Added information regarding primary/secondary windows and main reinforcing bars.
03-06-03	Jun-23	Added information regarding primary/secondary windows and main reinforcing bars.
03-06-04	Jun-23	Added information regarding primary/secondary windows and main reinforcing bars.
03-06-05	Jun-23	Added information regarding primary/secondary windows and main reinforcing bars.

**Section 3 SIM-ESIG  
Sequence List**

03-06-06	Jun-23	Added information regarding primary/secondary windows and main reinforcing bars.
03-06-09	Apr-23	Updated detail
03-06-10	Mar-23	Added anchor bolt details
03-06-12	Feb-16	No Change
03-06-13	Mar-23	Updated box pad dimensions
03-06-14	Jun-23	Removed bearing and backfill testing requirements.
03-06-14.1	Jun-23	New Spec
03-06-14.2	Jun-23	New Spec
03-06-15	Jun-23	Removed concrete design and testing submittal requirements.
03-07-11	Jun-20	No Change
03-07-11.1	Jun-20	New spec
03-07-11.2	Jun-20	New spec
03-07-11.3	Jun-21	New spec
03-07-12	Jun-20	No Change
03-07-14	Jul-20	Created Spec
03-12-01	Oct-17	Added NEC meter box note
03-12-02	Jul-18	Specified support parts in 6. Materials
03-12-03	Aug-18	Clarified inspection procedures in 10. Inspected by DTE Electric Planning. Changed name of the group
03-12-04	Oct-17	Added NEC meter box note
03-13-11	Feb-16	Changed location of cable on padmount
03-14-17	Feb-16	Change SE&E to OH & UG Construction Standards and 2/0 to 3/0
03-14-18	Oct-17	Added NEC meter box note
03-14-19	Aug-18	Added Nordic Fiberglass, Inc. as approved vendor. Changed name of the group.
03-14-20	Oct-17	Added NEC meter box note
03-14-21	Oct-17	Added NEC meter box note
03-14-22	Oct-17	Added NEC meter box note
03-14-25	Jun-18	Moved 1-1/4" conduit to lower side of meter enclosure as shown in 5-3-19.1
03-15-1	Oct-17	Added NEC meter box note
03-15-2	Feb-16	Changed DTE Electric Planner
03-15-3	Feb-16	No Change
03-15-4	Oct-17	Added NEC meter box note
03-15-5	Oct-17	Added NEC meter box note
03-15-6	Oct-17	Added NEC meter box note
03-15-7	Oct-21	Updated drawings, material information, and notes
03-15-8	Oct-21	Removed room dimensions, updated notes